

DC Series

DC 360kW Power Dispenser

User Manual & Installation Instructions

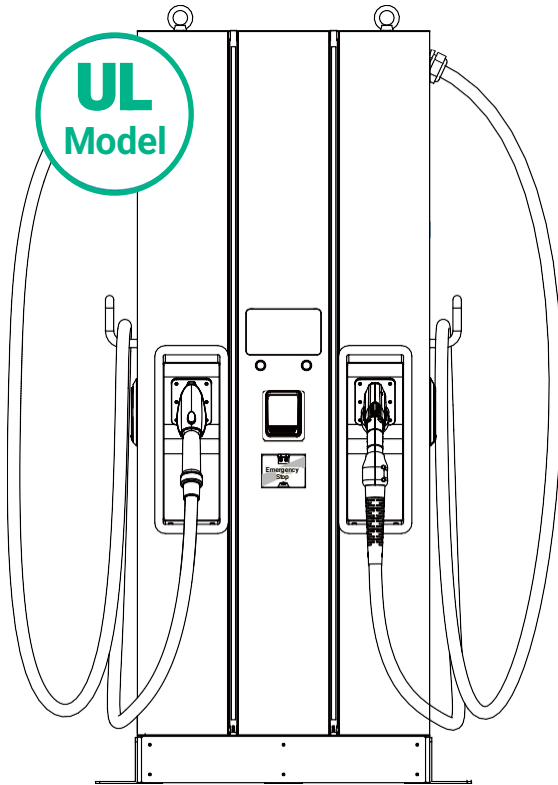

CONTENT

Introduction	1
Features	1
Applications	1
1. Basic User Interface	2
2. Specification	3
2.1 Product Specification	3
2.2 DDWx362 Series Version Description	5
2.3 LED Indication and Operation Status.....	6
2.4 Dynamic Power Sharing Info:	7
2.5 Dimensions.....	9
2.6 Direction of Cooling Airflow.....	9
3. Installation Instruction	11
3.1 Before Installation.....	11
3.2 Grounding and Safety Requirements	17
3.3 Install Sensor Board for Safely Shutting Down (Optional)	19
3.4 Unpack the Charger	23
3.5 Recommended Tools for Installation and Inspection.....	27
3.6 Installation Procedure	29
3.7 Installation Inspection & Commissioning	37
4. Operation Process	40
4.1 Operating Sequence	40
4.2 Operating Procedure	40
4.3 Troubleshooting	46
4.4 Status Codes.....	54
5. Maintenance	75
5.1 Before Maintenance	75
5.2 General Maintenance	75
5.3 Replacement Kits and Accessories.....	80
6. Limited Product Warranty	81
Appendix 1 - Package List	83
Appendix 2 - Maintenance Peroid	84
Appendix 3 - Standard Design Dispenser	85



Introduction

The Power Dispenser Fast Charger is the top choice to power battery electric vehicle (BEV) . It is designed for quick charging in both public and private locations, such as retail and commercial parking spaces, fleet charging station, highway service area, workplace, etc.

The Power Dispenser Fast Charger has the advantage of easy installation. The pluggable power modules realize flexible and cost-effective installation for different types of locations. The Power Dispenser charger also has network communication capability. It is able to connect with remote network systems and provide drivers of electric cars real-time information, such as the location of charging stations, charging progress and billing information. The Power Dispenser Fast Charger has a clear user interface with function buttons, safety certifications and an excellent waterproof and dust proof design to provide the best choice for outdoor environments.

Features

- Pluggable power modules make installation easy and flexible.
- Offers customers the convenience of start/stop charging control from an authorized RFID smart card or mobile APP.
- Built according the latest industry standards.
- Carries an outdoor rating capable of withstanding solid and liquid intrusions in outdoor settings making the unit more stable and highly reliable.
- Provides a high-contrast, screen interface with multi-function buttons.
- Upgradeable to simultaneously 4 DC charging, up to 360KW per output with liquid-cooled connector up to 500A

Applications

- Public and Private Parking Area
- Community Parking Area
- Parking Area of Hotel, Supermarkets and Shopping Malls
- Workplace Parking Area
- Charging Station
- Highway Rest Area



1. Basic User Interface

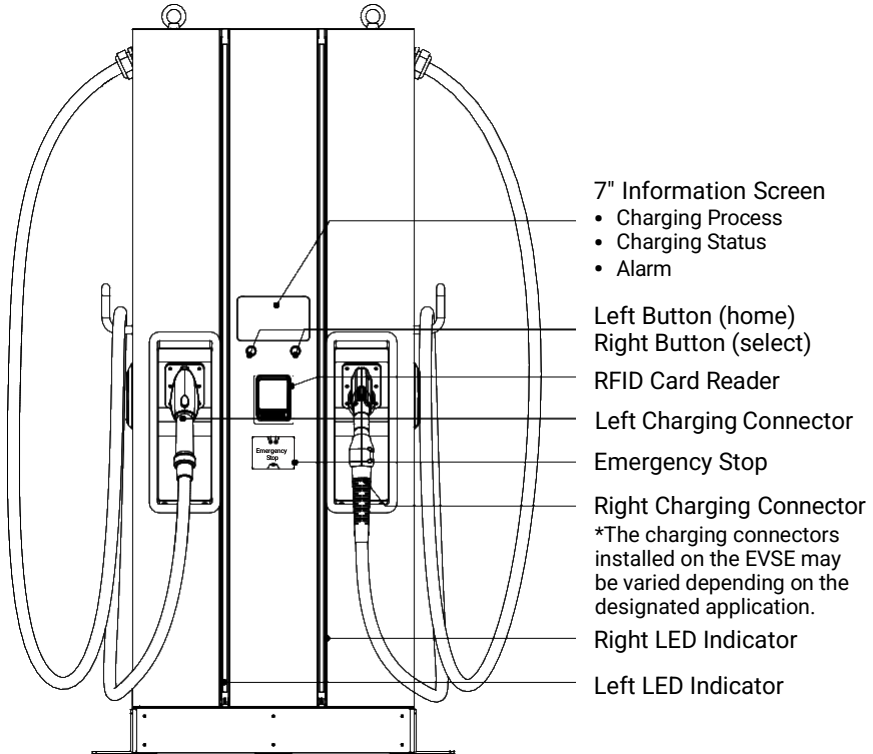



2. Specification

2.1 Product Specification

Model Name		DDWx362 Series
AC Input	Input Voltage	1Φ, 277 Vac (+10%, -15%)
	Input Current Rating	1Φ, 6.1 A
	Electrical Distribution	1P+N+PE (Wye configuration)
	Power Grid System	TN/TT
	Frequency	50/60Hz
DC Input	Maximum Input Voltage	950VDC
	Simultaneously Input Mode	0%, 25%, 50%, 75%, 100% of 360kW
	Voltage Accuracy	±2%
	Current Accuracy	±2%
DC Input Power Cable	Please refer to chapter 3.4.1 of power cabinet user manual	
DC Output	Output Voltage Range	DC 150~950 (CCS) DC 150~500 (CHAdEMO)
	Maximum Output Current	** Liquid Cooling CCS1/CCS2 500A@150Vdc ~ 720Vdc when output voltage up to 950Vdc the output current is 380A **Natural Cooling CCS1/CCS2 Combo, ** Single output mode 200A@150Vdc-950Vdc Option: 300A@150Vdc-950Vdc **CHAdEMO 200A@150Vdc ~ 500Vdc



	Maximum Output Power	360kW
	Simultaneously Output Mode	0%, 25%, 50%, 75%, 100% of 360kW
	Voltage Accuracy	±2%
	Current Accuracy	±2%
Maximum distance between power cabinet and dispenser	30M	
Standby Power	< 100W	
Communication	External	Ethernet
	Internal	CAN/ RS485
Output Protection	SCP, OCP, OVP, LVP, OTP, IMD	
Internal Protection	OTP, DC contactor detection	
User Interface & Control	Display	7-inch LCD
	User Authentication	RFID: Support ISO 14443A/B, ISO 15693, FeliCa Lite-S (RCS966), Backend: OCPP, APP, Mobile Payment
	Backend Support	Please refer to the user manual of cabinet
Environmental Conditions	Operation Temperature	-30°C to 50°C (-22°F to 122°F)
	Storage Temperature	-40°C to 70°C (-40°F to 158°F)
	Relative Humidity	5%~95% RH, non-condensing
	Altitude	≤ 2000m(6561ft)
Regulations	Safety	UL2202, UL2231
	EMI/EMC	FCC CFR Title 47 Part 15 Subpart B: 2020 ANSI C63.4: 2014 ICES-003:2020 Issue 7



Mechanical Specifications	Dimensions (WxDxH)	700 x 550 x 1800 mm (27.56"x21.65"x70.87")
	Weight (typ.)	< 300 kg(661.39lb)
	DC output interface (The interface may be different depend on the connector.)	Refer to Chapter 2.2 Table
	Cooling	Liquid: Liquid cooling Natural: Forced air
	Ingression Protection	NEMA3R
	Anti-vandalism	IK10, excluding LCD & RFID cover

2.2 DDWx362 Series Version Description

The DDWx362 Series are available in different versions depending on the charging connectors, below table shows the available combinations, the corresponding position of charging connectors are indicated from left to right when face to charger.

For example,

Version	CHAdEMO	CCS2 Liquid	CCS2 Natural	CCS1 Liquid	CCS1 Natural 200A	CCS1 Natural 300A
DDWx362 V0U				X	X	
DDWx362 V0T				X		X

U : Natural cooling CCS1 combo

V : Liquid cooling CCS1 combo

E : Natural cooling CCS2 combo

F : Liquid cooling CCS2 combo

G : GB/T DC

T : Natural cooling CCS1 300A

D : Natural cooling CCS2 300A

K : CHAdEMO 200A



2.3 LED Indication and Operation Status

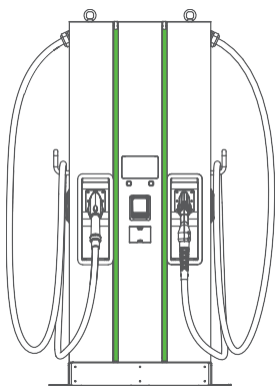

Standby

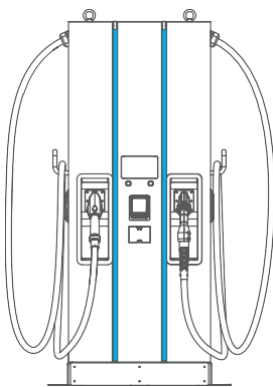

Charging

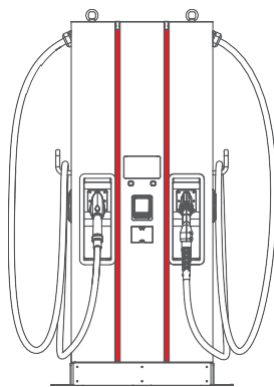

Abnormal

Status	LED	Left Indicator	Right Indicator
Standby		Green	Green
Charging		Blue	Blue
Abnormal		Red	Red



2.4 Dynamic Power Sharing Info:

Dynamic Power Sharing (Four-Connector Model Only). According to the standard 360kW power cabinet DC output, the power dispenser connectors maximum output as below list:

1. The connectors will get full 360 kW when only one connector is plugged in or the rest three connectors finish the charging session.
2. Each connector will get 180kW (50%) or 90kW (25%) and 270kW (75%) output power when Two connectors are plugged in simultaneously or the rest two connectors finish the charging session, depends on the electronic vehicles' charging power request.
3. The connectors will get 90kW (25%), 90kW (25%) and 180kW (50%) output power when Three connectors are plugged in simultaneously or the fourth connector finishes the charging session, depends on the electronic vehicles' charging power request.
4. The connectors will get equal sharing (90kW each) output power when Four connectors are plugged in simultaneously. If any particular specification, please contact the manufacturer for more information.

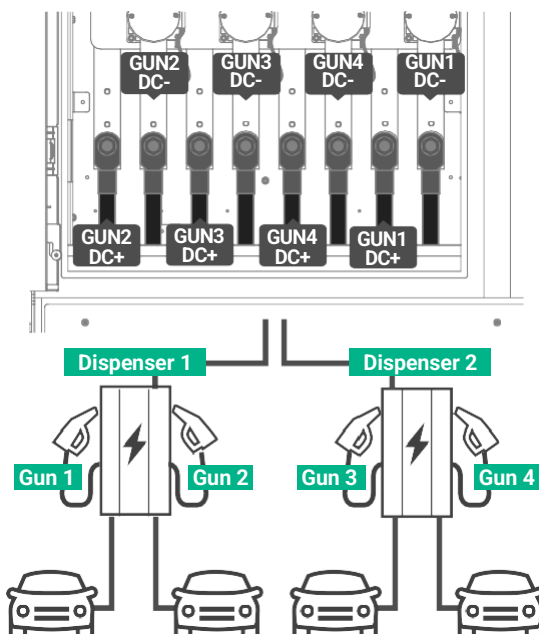



Cable Connection (TN system):

*Adapted for two cabinets version

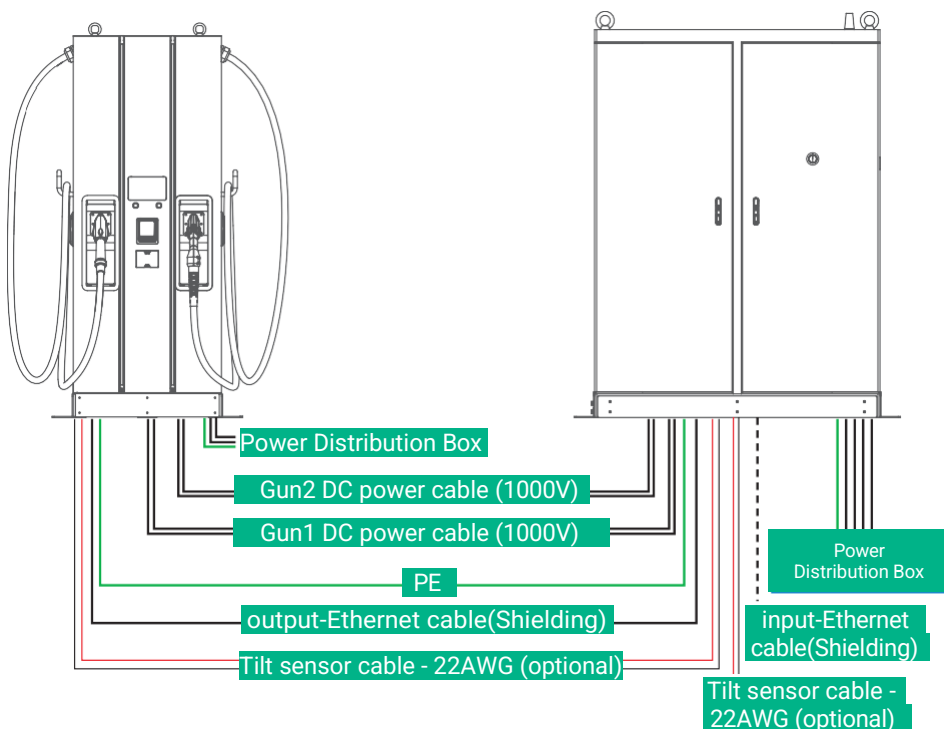

NOTE:

- The maximum DC voltage would be 950Vdc, the DC power cable be used should be able to withstand at least 1000V and required safe ampere capacity.
- Please note and confirm that all installation assemblies must comply with national safety standard and codes.
- The max. allowable distance between the power cabinet and the dispenser is 30m.
- The power cabinet and the distribution box are recommended to keep distance from the end users to have better operation experience.
- The similar design concept in appearance is recommended to the power cabinet and the distribution box.
- Must use the CAT6 SFTP cable 24AWG or 26AWG with CAT6A FTP RJ45 Plug or higher level cable/PLUG increased shielding for ethernet contact.



2.5 Dimensions

Unit: mm(inch)

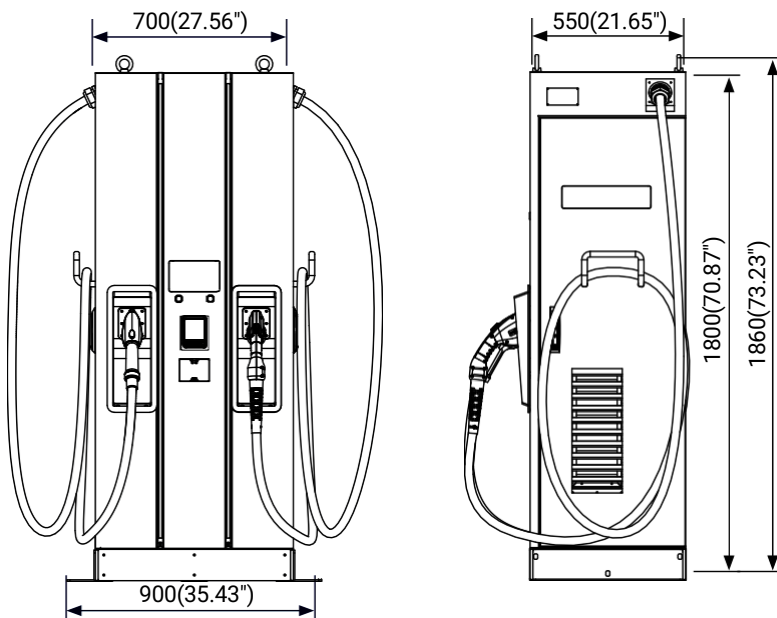

2.6 Direction of Cooling Airflow

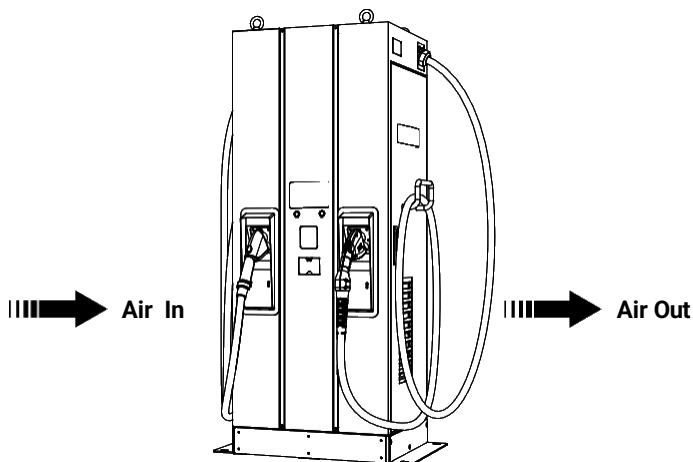



The following signs are used on the equipment and in this manual:



DANGER
Hazardous voltage

Identifies a hazard that could result in severe injury or death through electrocution.



WARNING
Various

Identifies a hazard that could result in severe injury or death.



WARNING
Rotating parts

Identifies a hazard that could result in injury due to the presence of rotating or moving parts.



WARNING
Pinch Hazard

Identifies a hazard that could result in injuries in which some body parts are pinched or crushed.



CAUTION
Various

Identifies a hazard that could result in damage to the machine, other equipment, and/or environmental pollution.



NOTICE
Contains remarks, suggestions or advice.



3. Installation Instruction

3.1 Before Installation

- Read all the instructions before using and installing this product.
- Do not use this product if power cable or charging cable has any damage.
- Do not use this product if the enclosure is broken, open or has other damage.
- Do not put tools, materials, fingers or other body parts into the charger or EV connector.



WARNING: The product should be installed only by licensed contractor, and/or licensed technician in accordance with all building code, electrical codes and safety standards.



WARNING: The product should be inspected by a qualified installer prior to initial use. Under no circumstances will compliance with the information in this manual relieve user of his /her responsibilities to comply with all applicable code and safety standard.

- The dispenser aux power can be connected to 1 phase among L1, L2 or L3 to Neutral.
- The capacity of power supply should be higher than 2.5kVA in order to have function correctly.
- The product should be installed in well ventilated area and need sufficient space for product installation and maintenance keep at least 100cm(39.37") clearance distance to the product.
- Do not twist, swing, bend, drop or crush the charging cable. Never drive over it with a vehicle.
- Make sure that minimum bending radius of charging cable is not exceed.
- With coolant inside; make sure the product not be over-tilt or turn back.



NOTICE

It is recommended to conduct Wi-Fi and 3G/4G signal strength while charger installation. The RSSI (Received Signal Strength Indication) value is considered as good as higher than -65dBm. Poor connection quality might interrupt charging process or data transaction.



3.1.1 Contractor Safety Guide

Introduction

- A safe work environment for everyone - participants, installation and demolition crews, contractors and subcontractors.
- Ultimately, it is the responsibility of contractors to ensure the safety and safe work practices of their employees and subcontractors who may be working at the site on their behalf.
- This guide provides a simple reference guide with basic rules for implementation. This guide does not outline every single safety standard: it is designed to be a supplement to participants, contractors and subcontractors.
- Contractors, subcontractors and employees should cooperate with their employers and other persons in complying with safety regulations and instructions.

In particular, employees should:

1. Obtain the qualified authorization of the responsible unit in the construction area.
2. Work safely.
3. Not do anything to endanger themselves or other persons.
4. Use personal protective equipment as required and take reasonable care of it when it is not in use.
5. Report unsafe activities immediately to supervisors or the responsible person in control of the workplace.
6. Report all accidents and dangerous occurrences to the supervisor immediately after they happen.



1. Requirements for workplace conditions

- Set up suitable fencing to isolate the construction area from outside
- Close and secure all entrances when the site is unattended
- Hang warning notices nearby which show the following information: warning icon and phone number of person in charge
- Install sufficient lighting fixtures



- Keep work areas (including accessways) free from debris and obstructions
- Keep ground surfaces tidy and flat, to avoid people tripping or being hurt by tools or other objects
- Stack and store equipment and materials in a tidy and stable manner
- Regularly clean up and dispose of waste
- Remove all surplus materials and equipment after completion of work



- Beware of flammable materials and goods. Keep them away from work areas.





4. Protection against high temperatures on the worksite

- Erect a sunshade or shed to shelter workers from the heat and sun
- Set up cooling equipment, such as exhaust fans
- Make water dispensers available
- Provide suitable protective clothing such as hat, sunglasses and long sleeves to protect workers from heat stroke and UV rays



5. Inclement weather

- Secure all scaffoldings, temporary structures, equipment, and loose materials
- Check and implement SOP to ensure disconnection of gas supplies, electrical circuits and equipment
- Inspect worksites to ensure protection against ingress of water or dust
- Inspect the drainage system for blockages and remove if found
- Stop all outdoor works except for emergency works



6. Ladders

- Only use ladders that meet local safety regulations
- Do not use wooden ladders
- When working at height, it is recommended to use platforms instead of ladders
- If using a platform is not practicable, a supervisor should assess the potential risk and provide safety



- protection equipment for workers
- Use non-conductive ladders made of glass-fiber or reinforced plastic when carrying out electrical work
- Assign assistants to provide support when working on ladders
- Check all ladders for broken rungs or other defects before use and periodically
- Fully open stepladders when in use
- Do not stand on the top two rungs of a ladder
- Do not overreach when working on a ladder
- Beware of overload restrictions



Country	Standards
British	BS1129,BS2037,EN131,EATS13/1
USA	ANSI A 14.1,ANSI A 14.2,ANSI A 14.5
Australia New Zealand	AS 1892.2-1922,AS/NZS1892.1,AS/NZS 1892.3
Canada	CSA Z11 M81

Common Standards for Ladders

7. Working at height

- Avoid working at height by using alternative tools and methods as far as practicable
- It is strongly recommended to build suitable scaffolding or work platforms
- Provide fall arrest systems for workers if it is impracticable to use working platforms
- Secure all materials and tools to prevent them falling from height

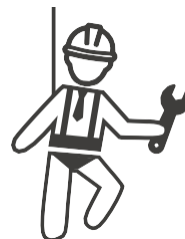



8. Lifting operations

- Have lifting gear and apparatus regularly inspected and tested by qualified persons
- Isolate and cordon off lifting areas to keep out non-construction personnel
- Ensure that lifting routes do not cross buildings or people, and avoid collision with objects
- Do not exceed safe working load limits



9. For on-site workers

- Plan all work
- Turn off power (work with live parts de-energized whenever possible)
- LOTO (Lock Out, Tag Out)
- Live electrical work permit (input terminals with HV after door open)
- Use personal protective equipment (PPE)
- Safe workplace conditions and space
- Adhere to other occupational health, safety and security codes, such as those published by OSHA



10. Reference standards

Adhere to the following codes:

- NFPA-70E -2021 Sec 110.3 (Electrical Safety in the Workplace)
- NFPA-70E -2021 Sec 130.4 (Shock Risk Assessment)
- NFPA-70E -2021 Sec 130.5 (Arc Flash Risk Assessment)





3.2 Grounding and Safety Requirements

- The product must be connected to a grounded, metal, permanent wiring system. Connections shall comply with all applicable electrical codes. Recommend ground resistance is less than 10Ω .
- Ensure no power is connected at all time when installing and maintaining.
- Use appropriate protection when connecting to main power distribution network.
- Use appropriate tools for each task.



CAUTION: The disconnect switch for each ungrounded conductor of AC input shall be provided by installation contractor or technician.



CAUTION: A cord extension set or second cable assembly shall not be used in addition to the provided cable assembly for connection of the EV to the EVSE.



3.2.1 Service Wiring

- Ground Connection

Always connect the Neutral at the service to Earth Ground. If ground is not provided by the electrical service then a grounding stake must be installed nearby. The grounding stake must be connected to the ground bar in the main breaker panel and Neutral connected to Ground at that point.

- 277 Vac Single Phase (L-N-PE)

CAUTION!



This is feed from Wye-connection power grid, the Power Dispenser Fast Charger can connect to one of L1, L2 or L3, and Neutral. Earth ground must be connected to neutral at only one point, usually at the breaker panel.

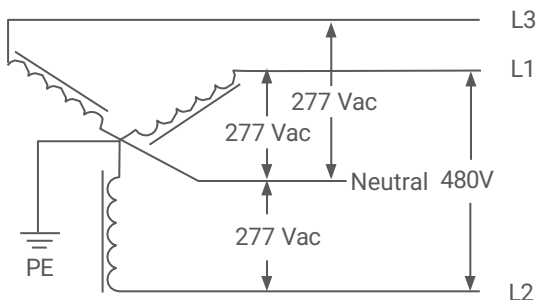

480V Three-Phase Wiring Connection



DANGERS

Be Aware of High Voltage!



WARNING!

Earth Connection is Essential!



3.3 Install Sensor Board for Safely Shutting Down (Optional)

1. **Introduction:** To prepare a control board which includes door sensor sensing function and tilt sensor, also dry contact points for extending wiring to upstream circuit breaker in order to cut off power immediately when sensors triggered. This board also has self-test button which uses to verify if it functions properly no matter in production line or in installation site or during regular maintenance service.

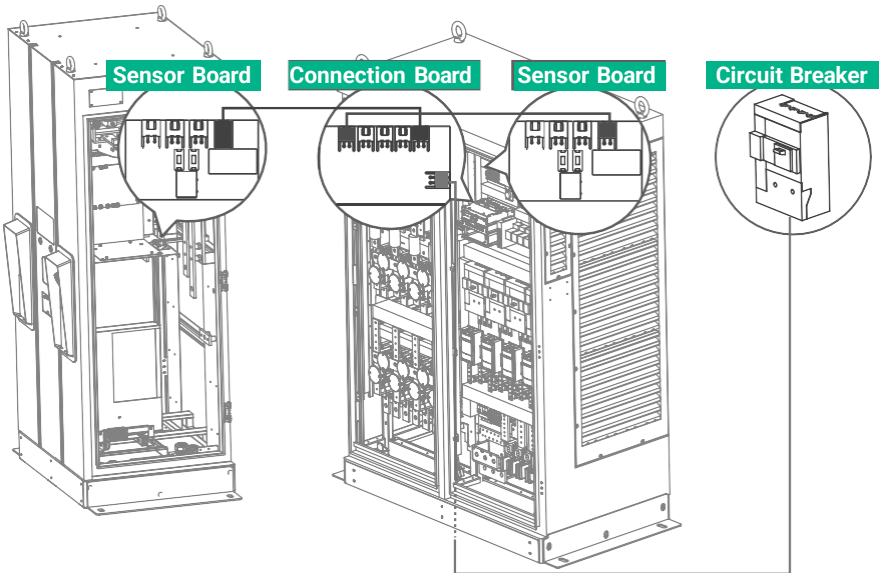

2. Function Block Diagram:

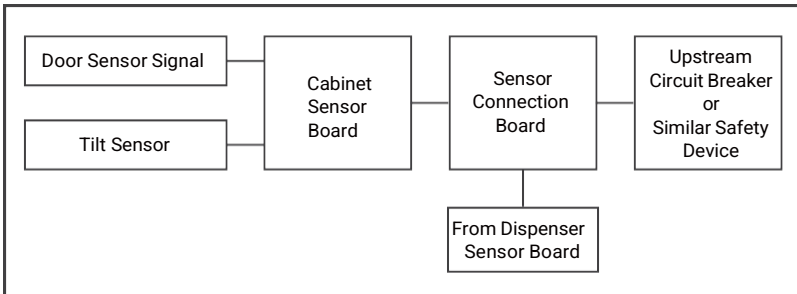



3. Sensor Board:

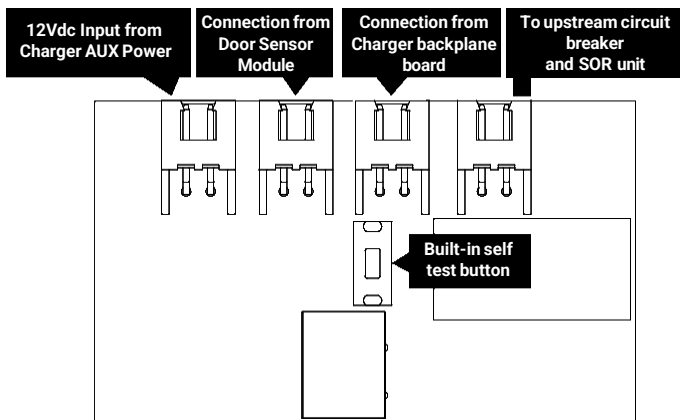

4. Control logic

- a) When either door sensor or tilt sensor has been triggered, it will send a voltage to trip off or open or cut off power of upstream circuit breaker. It is also known as “shunt release” which can be researched more over the internet.

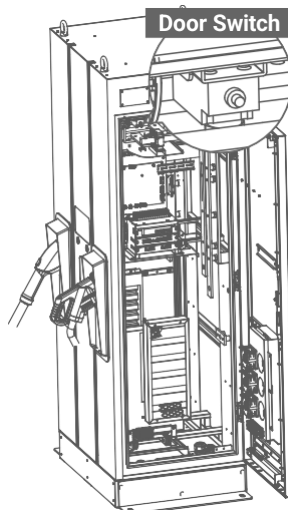
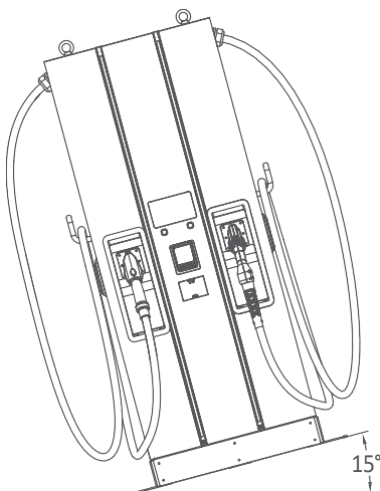



- b) When upstream circuit breaker been cut off, the charger will be totally shut down then goes into “off line” status immediately, it won't be recover remotely, only relies on service people to be presented on site.
- c) This board has self-test button which is able to test if it functions properly no matter in production line or in installation site or during regular maintenance service.

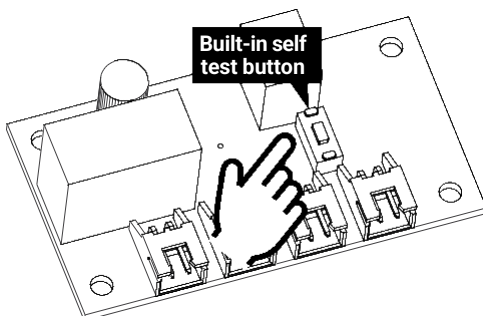

5. Sensor Board connetion Functions:

- a) Power cabinet and dispenser tilt sensor signal combination
- b) When the separate cabinet triggers a signal, notify the client to link breaker

6. Upstream circuit breaker selection and aux power preparation:

Constructor or CPO is mandatory to select a circuit breaker which with “shunt release accessory” or relevant devices so that the safety function can be activated. If you need any recommendation models of shunt release, please contact your local agent. Below are reference SOR reference models from ABB:

12V : SOR-C 12V DC (1SDA066321R1)

24V : SOR-C 24-30V AC/DC (1SDA066322R1)

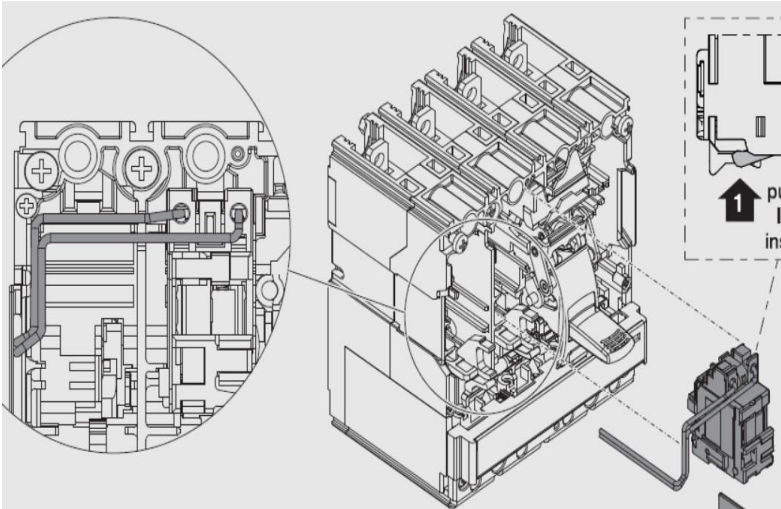

NOTICE

For the parts of SOR, maximum 277Vac withstand voltage is required.

7. Wires Spec Selection:

The wires from sensor board to upstream circuit breaker is recommended UL1015 22AWG 105°C 600V or relevant.

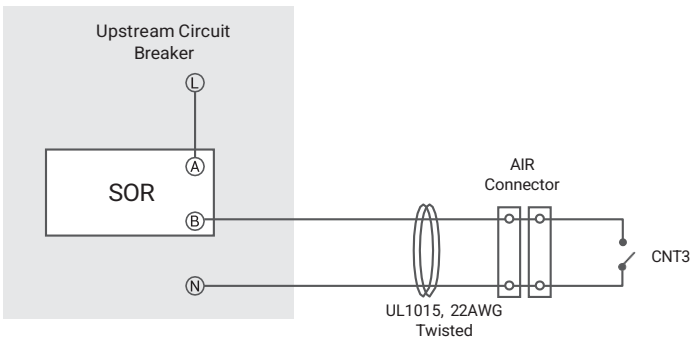

Control Circuit



3.4 Unpack the Charger

- The product is Direct current (DC) charger, the packing design passed the packaging simulation test, if the packaging is damaged cause by overturning, falling or external impact during transportation, it may cause the product damage or defects. if there is any serious damage to the packaging when receiving the goods, please notify manufacturer about your findings.
- Receiving the DC 360kW Power cabinet. The product is delivered by a transport company to a warehouse or specified location where it will be handed over. Transporting the DC 360kW Power cabinet to its final location (last mile service) is not standard included in the order.

NOTICE: The delivery truck unloads the pallet carrying the DC 360KW Power Cabinet. The movement of the DC 360kW Power cabinet to its final location is the responsibility of the customer / contractor.



- Checking the TiltWatch PLUS sensors: If the TiltWatch PLUS indicator is tilted over 30°
 1. Do not refuse the delivery / receipt.
 2. Make a notation on the delivery receipt and inspect cabinet for damage.
 3. If damage is discovered, leave cabinet in original package and request immediate inspection from carrier within 3 days of delivery.
 4. Contact manufacturer by mail or phone to notify us about your findings



WARNING!

Charger weight with packing may > 300 kg(661.39lb)!
Be careful during unpack process.



STEP 1.

Please disassemble the shipping crate as follows:

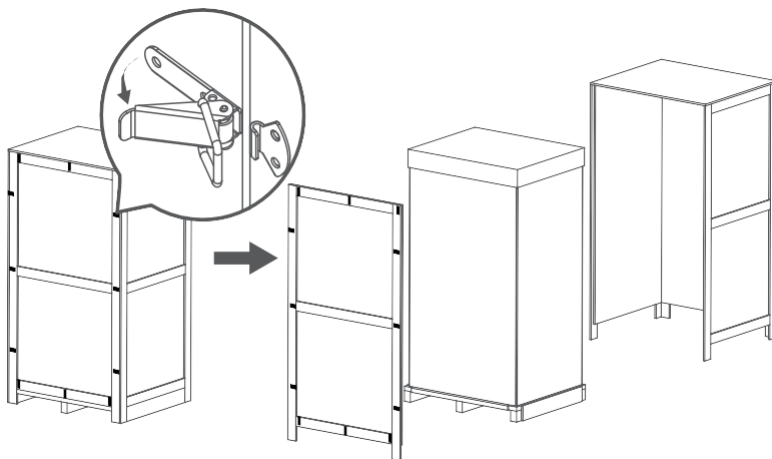

Please remove the cardboard box and the protective internal packaging as follows:

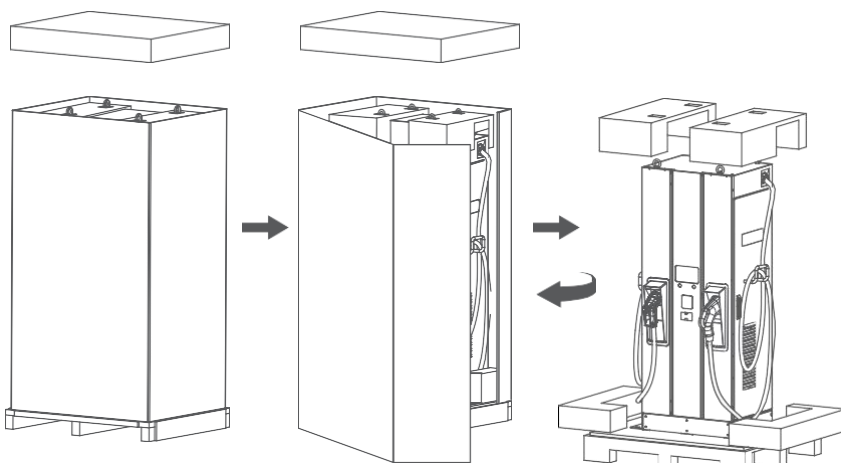



STEP 3.

Remove the 4 fixing screws.

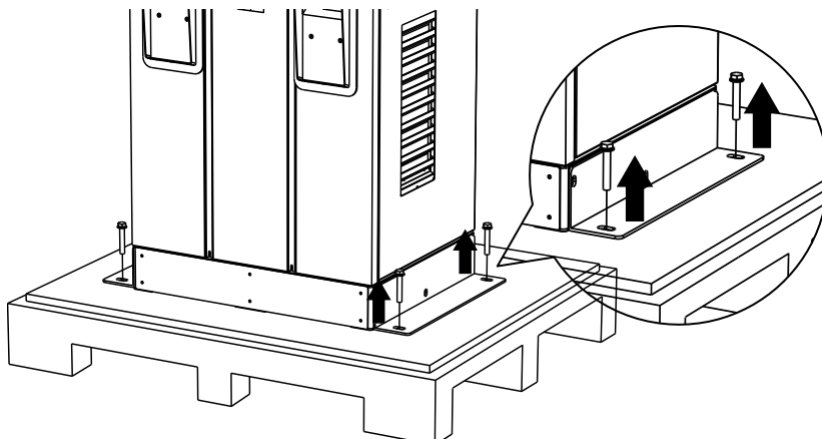

STEP 4.

To use lifting eye bolts to move the EVSE, please apply 6mm (1/4 inches) diameter steel wire rope to the four eye bolts as following picture.
(Make sure to tighten the eye bolts before lifting.)

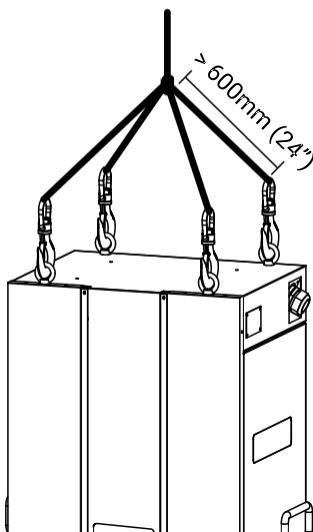



Or use a forklift to move the EVSE.

Step 1. Please remove the front and rear bottom trim panels first.

Step 2. Use a forklift to raise the EVSE.

(the fork must be opened to the maximum state)

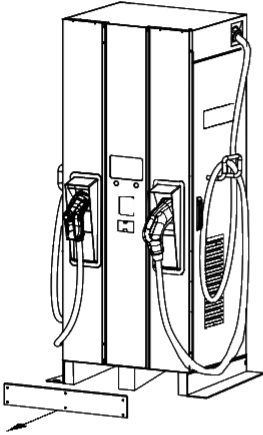

Step 1

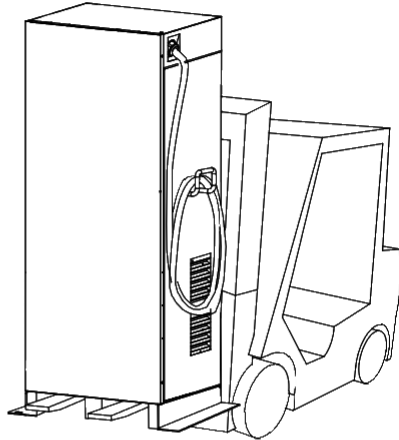

Step 2

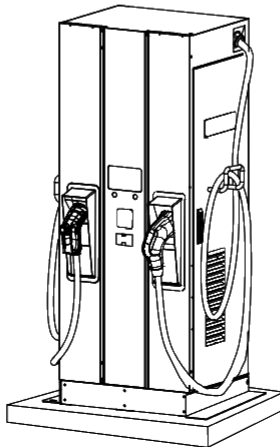



3.5 Recommended Tools for Installation and Inspection

3.5.1 Recommended Tools and Assemblies for Installation

Type	Description
Philips Screwdriver	No. 2
Hexagon Screwdriver	M12,M16
Shifting Wrench	8" (24mm)
Electrical tape	Black/15mm (0.6") Width
AC Input Cable	2.5mm ² or AWG12, Cable x 3 (L, N, PE) With Ring terminal for M5 screw (Inner diameter > 5mm (0.2"), Outer diameter < 12mm (0.47")) Recommend to use 600V, 75° C (167°F), XLPE/XHHW-2/ Hypalon/Photo-Voltaic power cable.
DC Input Cable	DC Output x2 (Gun1, Liquid cooling ; Gun2, Natural cooling)(The charging connectors installed on the EVSE may vary depending on the designated application.) Each connector is recommended to use below cable: Liquid 500A CCS1/CCS2-Conductor cross section: Conductor cross section: 250kcmil(127mm ²) at least, Cable x 4 (DC+ x2, DC- x2) Natural Cooling 300A CCS1/CCS2- Conductor cross section: 350kcmil(177mm ²) at least, Cable x 2 (DC+ x1, DC- x1) Natural Cooling 200A CCS1/CCS2, CHAdEMO 200A Conductor cross section: 3/0 AWG kcmil(85.01mm ²) at least, Cable x 2 (DC+x1 , DC- x1) With ring terminal for M16 screw(Inner diameter >16mm (0.63"), Outer diameter < 40mm (1.57") ; Thick type)  Recommend to use 600V, 75° C (167°F), XLPE / XHHW-2/ Hypalon / Photo-Voltaic power cable.



	 <p>Protective Earth conductor: Conductor cross section: (2 AWG) cable for TN system With ring terminal for M16 screw (Inner diameter > 16mm (0.63”), Outer diameter < 36mm (1.42”) ; Thick type) (Conductor cross section: (2 AWG) round rod for TT system) * Suggest to use concrete culverts for underground cable layout due to 1000V application .</p>
Ethernet cable	CAT6 SFTP cable 24 AWG or 26 AWG x 2 for dispenser cabinet
Slotted Screwdriver	
Socket driver	
Forklift	
Wire Stripper	
Wire cutters	
Residual Current Device	30mA type A, 2 pole
MCCB(Moulded Case Circuit Breaker)	Curve B (for capacitive load)



Please consult your local electrical technicians for proper installation instructions as installation requirements or conditions may vary on-site.

3.5.2 Recommended Tools for Inspection & Commissioning

Type	Description
EV or EV Simulator	Meet CHAdeMO/CCS Standard
Multi-meter	1000V
Current Probe	500Amp at least
RFID Authorized Card	
RFID No Valid Card	
Door Key	
Needle-Nose Plier	
Torque Meter screwdriver	
Laptop & CAT 6 cable	
Wi-Fi, 3G/4G signal quality checker	Recommended



3.6 Installation Procedure

3.6.1 Required Space for Placing and Maintaining

required a space of 2400x1800 mm. This space is calculated as follows:

- Size Charge W x D x H: 550 x 700 x 1800 mm.
- Front side 850 mm, for user operating.
- Left and right side 550 mm, in order to open left and right door.
- Backside 1000 mm, in order to open the back door.

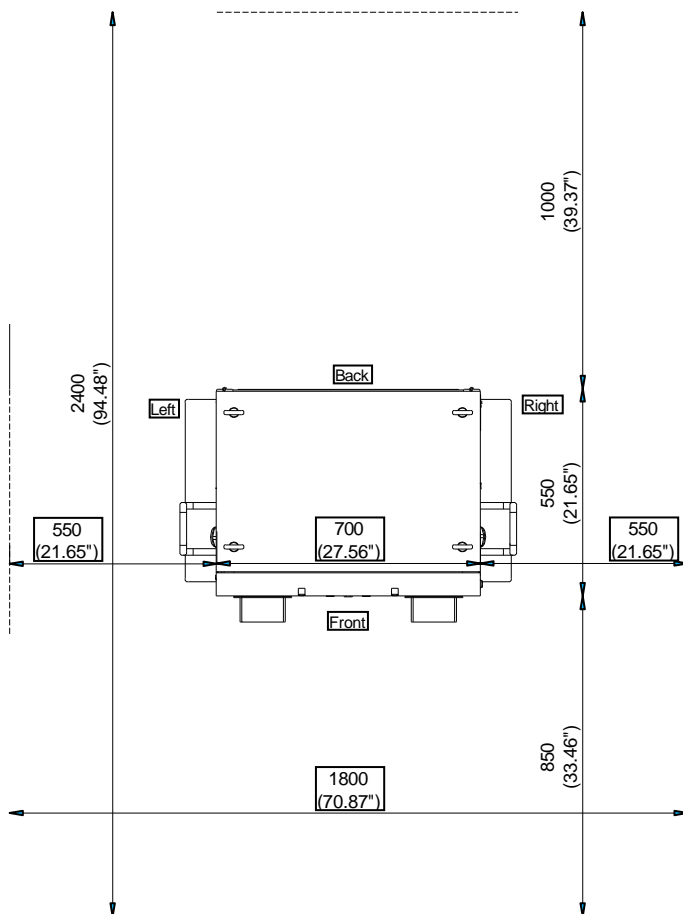



3.6.2 Build Concrete Base

STEP 1.

- Build 1100mm(43.31") x 750mm(29.53") x 200mm(7.87") RC concrete base in advance; Φ 40mm conduit for input AC cable, Φ 120mm conduit for input DC cable, Φ 40mm for communication cable (Ethernet) and 1" drain pipe.
- Install the 4 pcs of M12 mounting anchor bolts and leave at least 40mm(1.57") thread length enough for 2 pcs of M12 nuts to be fasten on each after the unit has been fitted onto the base. The positioning of these 4 pcs of M12 screws should be within ± 2 mm in short axis, ± 14 mm in long axis according to screw holes of charger. Add drain pipe at opening of concrete base to prevent standing water.
- Recommend to use a prefabricated steel mould for constructing the cement concrete base per dimensions provided below.

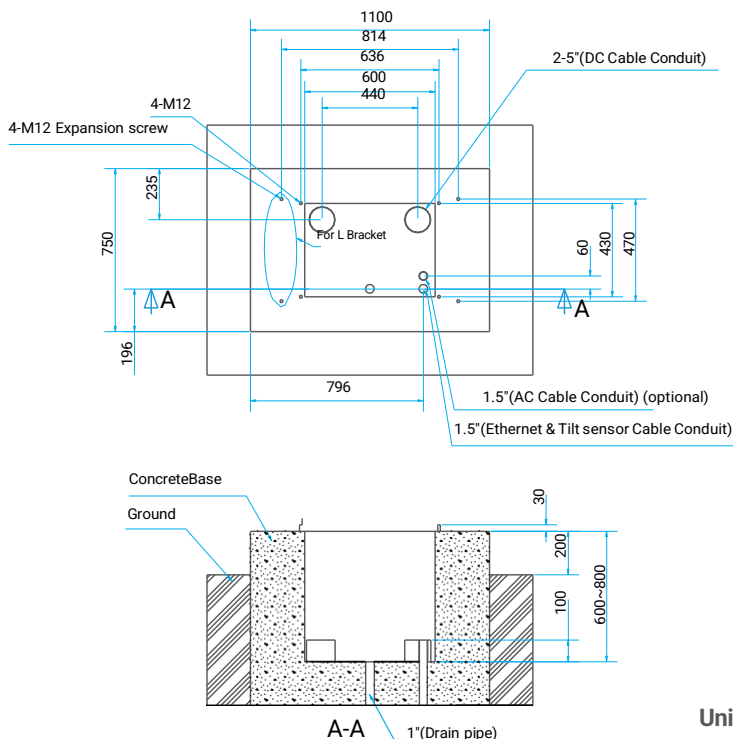

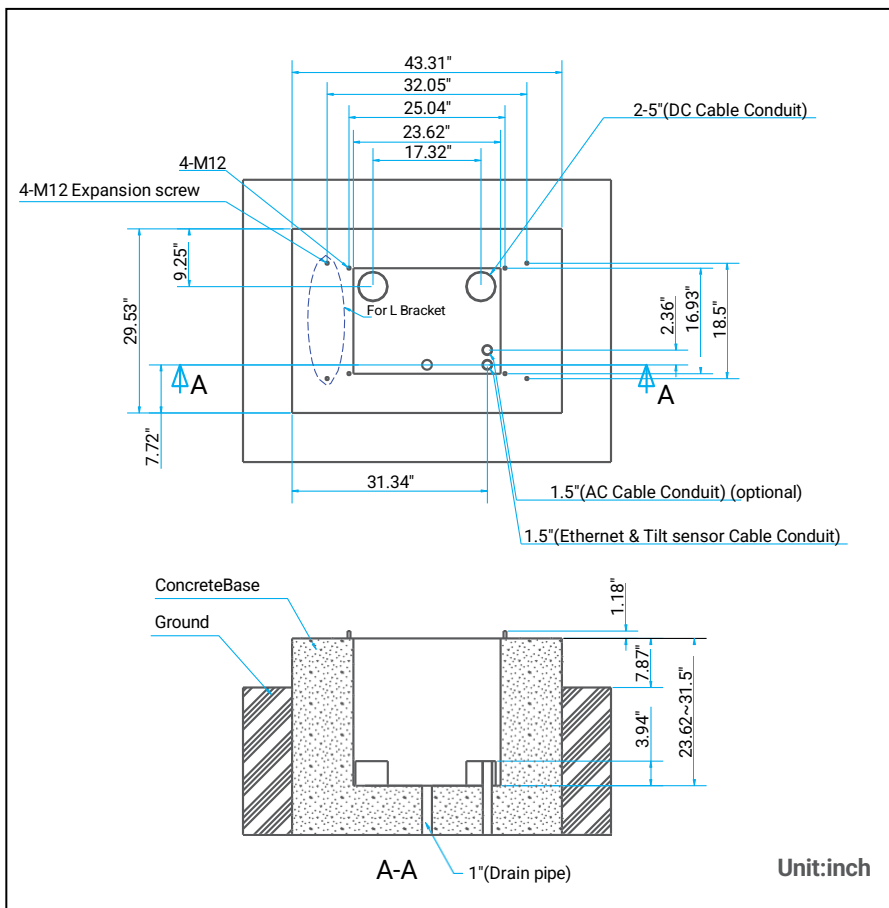

STEP 2.

- Extend 1 phase 3 wires AC input cable from conduit of concrete base, AC cable expose at least 270mm(10.63") and be with ring terminals. The conductor cross sectional area of input power wires should be not less than 2.5mm² AWG12.
- Extend 2 sets DC power cable from conduit of concrete base, Gun1 DC+ cable expose at least 840mm(33.07"), DC- cable expose at least 910mm(35.83"); Gun2 DC+ cable expose at least 840mm(33.07"), DC- cable expose at least 620mm (24.41")and be with ring terminals.
- Extend Ethernet cable from conduit of concrete base, expose at least 1350mm(53.15").



***keep at least 100cm(39.37") clearance distance for the cabinet**

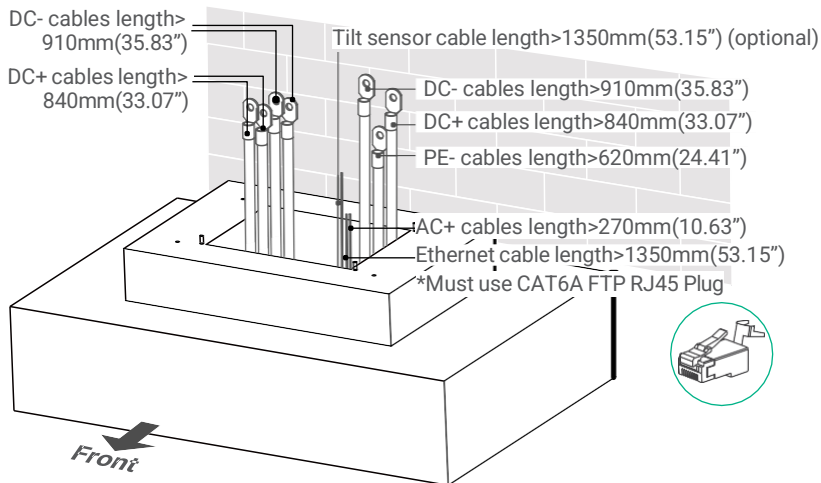

3.6.3. Two Methods of Fixing the Charger

Method 1.

Fix the cabinet with internal screw.

Lift the charger onto the concrete base, feed all the cables through the entry hole located at the bottom of the unit; fasten the 8 pcs of M12 screw nuts on the 4 pcs of M12 mounting anchor bolt from the cement base (2 nuts for each bolt) to secure the chargers.

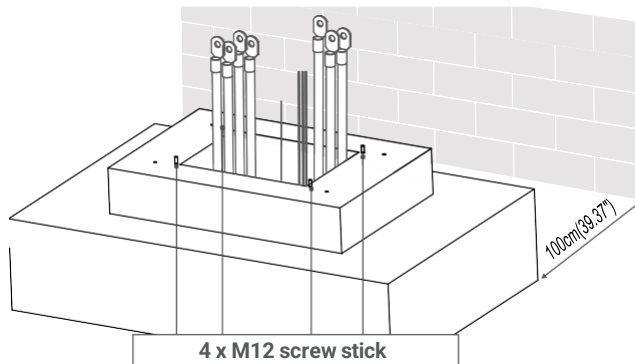



Method 2.

Fix the cabinet with external brackets and expansion bolts.
Lift the cabinet onto the concrete base, remove the cover metal sheet of the cabinet base, fix the L-shaped brackets on the cabinet base with the M12xL130 expansion screws (Material: Stainless steel), drill 4x Φ 12mm screw holes on the concrete base, secure L- shaped brackets on the concrete base by 4 pcs M12 expansion bolts.

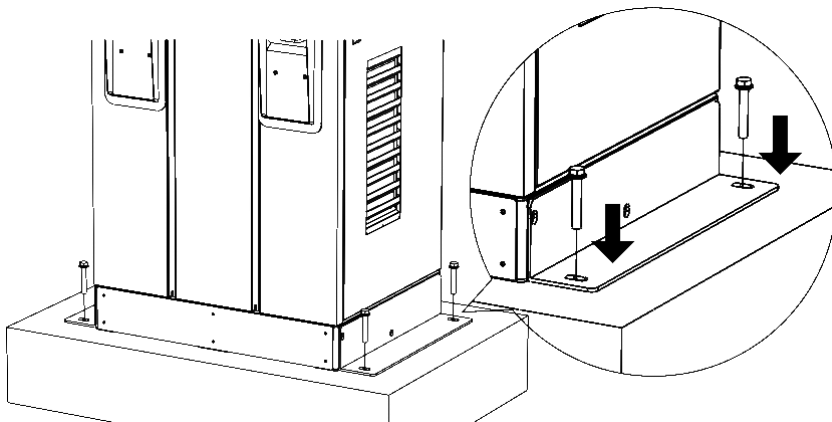

NOTE

If remove the eye bolts on the top of the cabinet, must assemble the waterproof plastic bolts Inside (in the accessory pack).

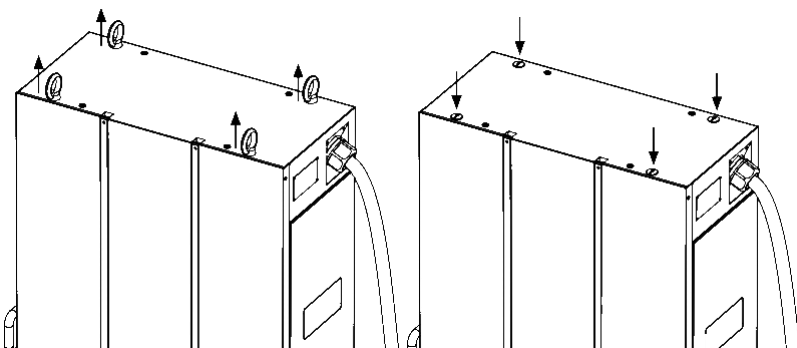



3.6.4 Installing Cables

STEP 1.

Fasten the PE cable to grounding plate of cabinet; connect AC input Line cable , Neutral cable and PE cable to terminal block. Fasten DC+ and DC- cables from power cabinet to paired busbar.

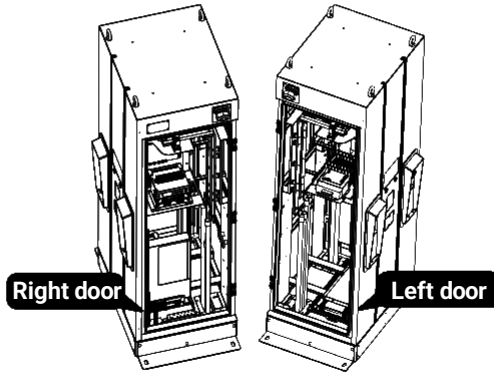

Left Door

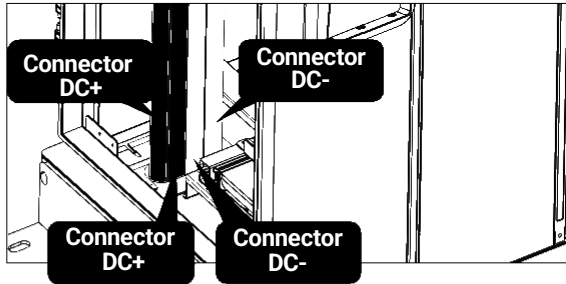

*The charging connectors installed on the EVSE may vary depending on the designated application.

Right Door

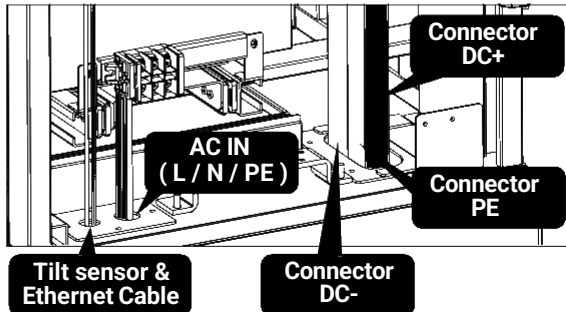

*The charging connectors installed on the EVSE may vary depending on the designated application.



STEP 2.

Connect Ethernet cable to RJ45 port of CSU.

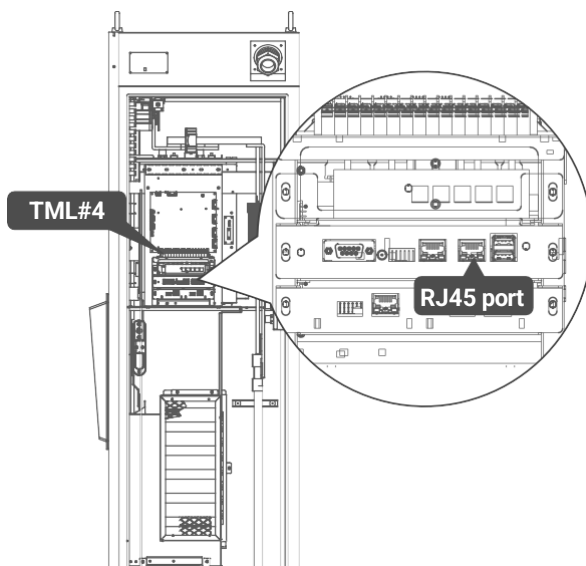

STEP 3.

Connect AC power cables to power distribution box, connect the Protective Earth wire (Green/Yellow) to ground point of power distribution box. Neutral should be shorted with ground point to meet TN(-S) grounding system.

STEP 4.

Use adaptive flame retardants and electrical insulated foaming agent and far from conductive live part at least 12mm AWG 6 or other method to seal the cable entry hole to assure the NEMA3R grade of the cabinet, and prevent insects enter the cabinet.



A 20A MCCB for capacitive load and 30mA RCD type A is recommended to use on power distribution box.



3.6.5 Screw Torque Requirement Table

Screw in Metric						
Screw size	Screw type	Steel Inch-Lbs	Steel kgf-cm	Steel N-m	Aluminum kgf-cm	Aluminum N-m
M2*0.4	Machine	3~4.77	3.5~5.5	0.34~0.54	3~4.5	0.34~0.44
M2.5*0.45	Machine	3~4.77	3.5~5.5	0.34~0.54	3~4.5	0.34~0.44
M3*0.5	Machine	5.5~9	6.5~10.5	0.64~1.04	5.2~8.4	0.51~0.82
M3.5*0.6	Machine	8.5~13	10~15	0.98~1.47	8~12	0.78~1.18
M4*0.7	Machine	13~18	15~21	1.47~2.06	12~17	1.18~1.66
M5*0.8	Machine	25~34	29~39	2.84~3.82	23~32	2.26~3.14
M6*1.0	Machine	45~55	52~63.5	5.1~6.22	42~51	4.11~5
M6*1.0	Hex cap	85~112	98~129	9.6~12.65	78~103	7.65~10.1
M8*1.25	Machine	106~141	122~163	11.96~15.98	98~130	9.61~12.75
M8*1.25	Hex cap	205~274	237~316	23.24~30.98	190~253	18.63~24.8
M10*1.5	Hex cap	212~382	245~440	24.02~43.15	196~351	19.22~34.42
M12*1.75	Hex cap	372~668	430~770	42.17~75.49	343~615	33.63~60.3
Screw in Imperial						
2-56	Machine	1.5~2	1.7~2.3	0.17~0.22	1.4~1.8	0.14~0.18
4-40	Machine	3~4	3.5~4.5	0.34~0.44	2.8~3.6	0.27~0.35
6-32	Machine	6~10	7~11.5	0.68~1.13	5.6~9.2	0.55~0.9
8-32	Machine	10~15	11.5~17	1.13~1.66	9.2~14	0.9~1.37
10-32	Machine	16~24	18.5~28	1.81~2.74	15~22	1.47~2.16
1/4-20	Machine	35~46	40~53	3.92~5.2	32~42	3.14~4.11
1/4-20	Hex cap	57~77	66~89	6.47~8.73	53~71	5.2~6.96
5/16-18	Hex cap	119~158	137~182	13.43~17.85	110~145	10.77~14.21
3/8-16	Hex cap	205~274	237~316	23.24~30.99	190~253	18.63~24.82
7/16-14	Hex cap	338~451	390~521	38.24~51.09	312~416	30.59~40.79
1/2-13	Hex cap	515~686	595~792	58.35~77.66	476~634	46.68~62.17



3.7 Installation Inspection & Commissioning

3.7.1 Environmental Check

Item	Status	Remark
Ambient temperature		
Ambient humidity		
Sunshade		Recommended but not required
Rain canopy		Recommended for better charging experience and maintenance on rainy day
Air circulation / Drafty		
Dust level		
Anti-vandalism measures		National regulations
Flood measures		
Car bumper or bollard		

3.7.2 External Infrastructure Readiness & Check

Item	Status	Remark
Cement (stand) Base		
Input Wirings & Terminals		Type/ Length/cross section
Key & Lock of Cabinet Door		Type /No.
Fixing Screws		
MCCB(Moulded Case Circuit Breaker)		Current rating of MCCB shall be higher than or equal to 20A
Grounding Resistance		<10 Ω
Network Connection & Quality		

3.7.3 EVSE Check – Prior to installation/ energization

Item	Status	Remark
Outlook		No dent, rust ,scratch
Labeling & Warning Signs		
Package (Accessory) List		
Inner Wiring & Connection		Refer to 3.6.5
Robustness of Input Wirings		1. AC power cables



		2. RJ45 connector
Robustness of Output Wirings		DC power cables
Coolant		Level & No leakage
Dispense Cabinet ID		1 for single or left cabinet, 2 for right cabinet

3.7.4 EVSE Check - Power On

Item	Status	Remark
Screen Display		
Network Connection Quality		
LED Status Indication		
Cooling Fans Operation		
EVSE Setting		
Backend Server Connection		
Network Connection & Quality		

3.7.5 EVSE Check - Charging

Item	Status	Remark
User Authorization –RFID		
User Authorization –QR Code		
User Authorization –Others.		
Waiting Time of Connection Check		
Reading of Each Display Item		
Full Charge Test		
Function of Electronic Lock		
Airflow & Cooling Fan & cooling unit of charging gun		



3.7.6 EVSE Check –System Power Button

Item	Status	Remark
Emergency Stop Button & Recovery		Set the rated load state, press the emergency stop button, the charger should be cut off output immediately. <ol style="list-style-type: none"><li data-bbox="695 437 1000 549">1. The charger stops charging and alarm when press the emergency stop button.<li data-bbox="695 552 1000 663">2. When the button is released and the gun is pulled, the EVSE returns to standby status.
Tilt sensor and Door open sensor trigger & Recovery(Optional)		Push self-test button then upstream circuit breaker will be cut off.



4. Operation Process

4.1 Operating Sequence

- System Initialization
- User Authorization
- Plug in DC Charging Connector
- Preparing for Charging
- In Charging
- Charging Terminated
- Status Messages

4.2 Operating Procedure

4.2.1 System Initialization

- When the charger is powered on, it start with the “Charging Station” Initializing page.
- You will see the below image on the screen after powering on and the system is initializing.
- The initializing process will take around 2 minutes, then shows home page.

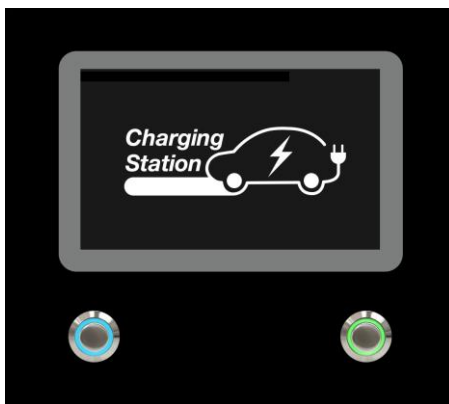

Initializing page



Home page

Unit and currency if billing function is enabled

- Ethernet Backend Status



- Wi-Fi Status



- 3G/4G Status



- OCPP Backend Status



4.2.2 User Authorization

- After the system is initialized the screen will stay at Home page as below illustrated.
- Use your RFID card or mobile app to authorize the use of the EVSE.



Home page

User authorization Method: RFID, QR code and mobile APP.

- Unauthorized method(s) will be darker on the screen if the method is disable.



User authorizing



User authorized.



Authorization failed

4.2.3 Plug in Charging Connector

- After authorization the screen will ask the user to plug the charging connector into the EV charging inlet as below illustrated.
- Take the Charging connector from the charging cable holder and plug the connector into EV charging inlet. The charger will automatically detect the type of the charging connector.
- It will normally take less than 10 seconds to start the process after completing the physical connection of charging connector to charging inlet. To terminate this session, please press the left button to return to the Home page

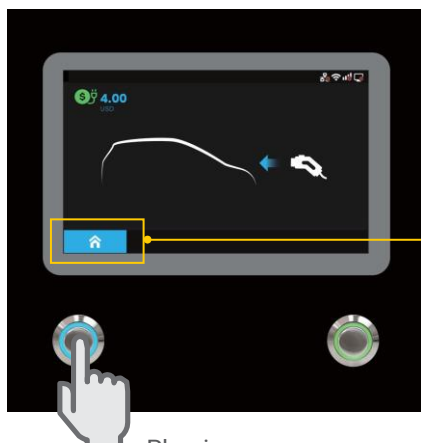

Press left button to terminate this charging session and then return to Home page.

Plug-in page



4.2.4 Prepare for Charging

- After authorization and plug-in process, the charger will start communicating with the vehicle and the screen will show the Preparing page as below illustrated.

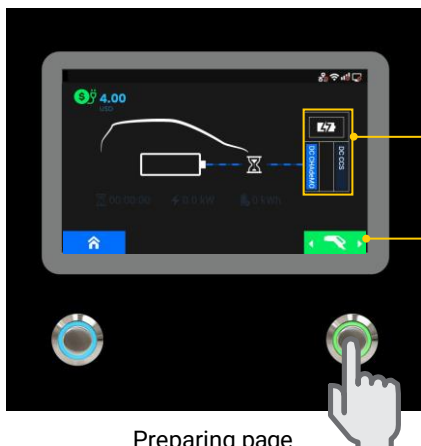

Preparing page

Information of Selected Charging Connector

Connector Select Button

Press right button to select the charger connector that the user would like to use.

4.2.5 In Charging

- The screen will show the Charging Page as below illustrated once the charger goes into the ready to charge stage.

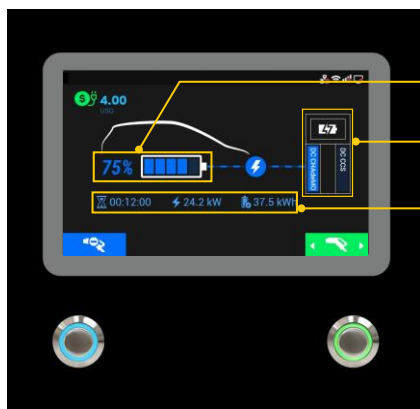

Charging page

EV battery SOC

Show the selected connector in use

Charging information area

 Charging duration,

 Charging power

 Energy



- When the battery has been fully charged or reaches the limit of the setting it will stop charging automatically and go to the next process.



Press right button to select the charger connector that the user would like to stop.

- User also can tap the RFID to stop charging.

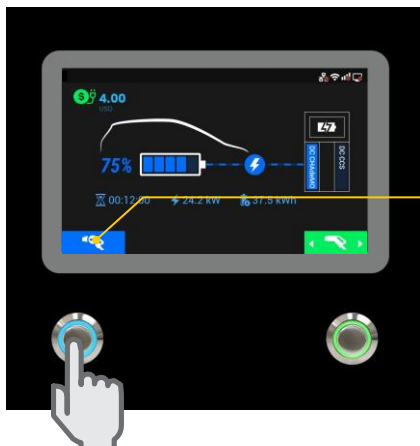

Tap RFID card or push stop button to stop



4.2.6 Charging Terminated



- After charging is terminated the charger system will show the Charging Summary page as below illustrated and the charging connector will automatically unlock.
- Unplug the charging connector from charging inlet of the EV and return the charging connector to charging cable holder.
- The screen will go back to the Home Page or the other charging connector's Charging Page if unplugged from the charging connector.
- During simultaneous charging the screen will go to the other charging connector's Charging Page if either charging connector is unplugged.

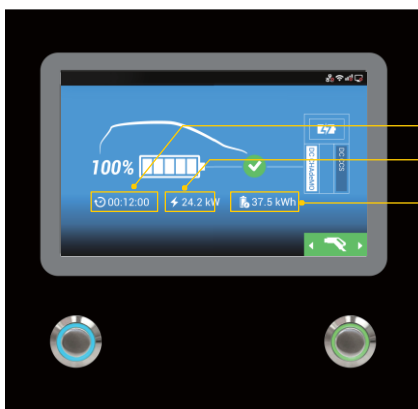

Charging duration

Charging power

Charging energy

Charging summary page

4.2.7 Status Messages

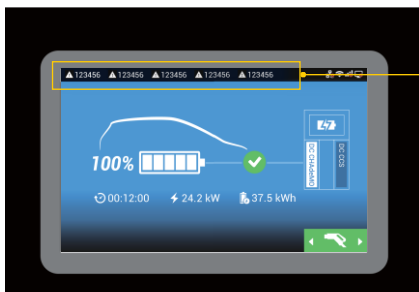

Status Code



4.3 Troubleshooting

- Please follow the instruction in the table when errors occur during the charging process.
- Or please connect the EVSE to the Internet and then contact the EVSE provider for further instructions.
- Please provide the EVSE information including serial number, model name, status code, failure behavior and timing, and also connect the EVSE to the Internet before remote diagnostics and upgrading.
- If an emergency occurs push the Emergency Stop Button to stop charging immediately.

4.3.1 Troubleshooting Guide for End User

When charging fault occurs, user may eliminate fault status by following steps.

Conditions	Troubleshooting guide
Black screen	Please contact your dealer.
Stuck on boot or service screen	Please contact your dealer.
Card tapping or QR code scanning failed	<ol style="list-style-type: none">1. Invalid RFID card or insufficient balance.2. Card reader failure or other faults; please contact your dealer.
Indication page returns from cable plugging to selection	<ol style="list-style-type: none">1. Please make sure the charging cable selection is correct2. Please make sure the charging cable has been plugged in completely with a “clicking” sound, and the gun button cannot be pressed.3. Please check the charge port indicator or meter whether the charge function is failed.4. Please try again with other chargers. If the situation keeps the same, the EV perhaps unable to charge, please send the EV for service.5. Charging cable or control guide invalidated, please contact your dealer.



Conditions	Troubleshooting guide
Indication page transfer from charging preparation to settlement directly	<ol style="list-style-type: none">1. Please unplug the charging cable and try again.2. Please check the EV charge port indicator or meter whether the target charging limit has been done or terminated before default charging time.3. Drive the EV away for few meters / feet and return, then try again.4. Please contact your dealer.
Indication page transfer from charging preparation to settlement directly	<ol style="list-style-type: none">1. Please unplug the charging cable and try again.2. Please check the EV charge port indicator or meter whether the target charging limit has been done or terminated before default charging time.3. Drive the EV away for few meters / feet and return, then try again.4. Please contact your dealer.
Stuck on SOC 100% or 0% settlement page without charging	<ol style="list-style-type: none">1. Please check EV charge port indicator or meter, whether full charged, the target charging limit is done or stopped before default charging time. *2. Please unplug the charging cable and try again.3. Please contact your dealer.
Charging complete but the charger did not release EV	<ol style="list-style-type: none">1. Please unlock the EV, press the button of HV charging port cover, and try to unplug again.*2. Turn the startup switch on and off, then try to unplug again.3. Lock the EV doors and release, then try to unplug again.4. Turn the EV air conditioner off, then try to unplug again.5. Please release by EV manual unlock switch.6. If there is no manual unlock, please turn off or reset the charger.7. Contact your EV company or dealer.



4.3.2 Troubleshooting - No Status Code

Conditions	Troubleshooting guide
Black screen	<ol style="list-style-type: none">1. Incorrect input power or connection fault, please supply power correctly and reset the power.2. Charger auxiliary power, display, or other faults. Please contact your dealer.
Stuck on boot or service screen	<ol style="list-style-type: none">1. System is in update or self-check procedure, please wait.2. Other faults of charger, please reset the power or restart the charger.3. Please contact your dealer.
Card tapping or QR code scanning failed	<ol style="list-style-type: none">1. Invalid RFID card or insufficient balance.2. Contact management staff to check internet connection between charger and Back-End server.3. Code scanning or Back-End authorization failed; please contact management staff.4. Card reader failure or other faults; please contact your dealer.
Indication page returns from cable plugging to selection	<ol style="list-style-type: none">1. Please make sure the charging cable selection is correct.2. Please make sure the charging cable has been plugged in completely with a "clicking" sound, and the gun button cannot be pressed.3. Please check the charge port indicator or meter whether the charge function is failed.4. Please try again with other chargers. If the situation keeps the same, the EV perhaps unable to charge, please send the EV for service.5. Charger control guide failed. Please turn off and restart the charger.6. Charging cable or control guide invalidated, please contact your dealer.



Conditions	Troubleshooting guide
Indication page transfer from charging preparation to settlement directly	<ol style="list-style-type: none">1. Please unplug the charging cable and try again.2. Please check the EV charge port indicator or meter whether the target charging limit has been done or terminated before default charging time. *3. Drive the EV away for few meters / feet and return, then try again.4. Charger handshaking failed, please reset, or turn off and re-start the charger.5. Please contact your dealer.
Stuck on SOC 100% or 0% settlement page without charging	<ol style="list-style-type: none">1. Please check EV charge port indicator or meter, whether full charged, the target charging limit is done or stopped before default charging time. *2. Please unplug the charging cable and try again.3. EV messages load failed. Please turn off and restart the charger.4. Please contact your dealer.
Charging complete but the charger did not release EV	<ol style="list-style-type: none">1. Please unlock the EV, press the button of HV charging port cover, and try to unplug again. *2. Turn the startup switch on and off, then try to unplug again.3. Lock the EV doors and release, then try to unplug again.4. Turn the EV air conditioner off, then try to unplug again.5. Please release by EV manual unlock switch.6. If there is no manual unlock, please turn off or reset the charger.7. Contact your EV company or dealer.

*Each model of EV contains different charging condition and gun release method, please refer to your user manual.

5.3.3 (011-XXX) Troubleshooting - Error Code

011-XXX contains charger's parts or connection fault message; please unplug charging connector, turn power off, reconnect the issued part and then power on the unit. If same error code be displayed, then must be serviced by qualified technician. Please contact your dealer.



4.3.4 Troubleshooting - Warning Code Form

Status Code	Conditions	Troubleshooting methods
012200 ↓ 012214	Abnormal input voltage	<ol style="list-style-type: none">1. Charging can be enabled after electrical grid supply regularly.2. Please check the input power or turn off and restart the charger.3. Please contact your dealer.
012223 ↓ 012232	Abnormal environment or devices temperature	<ol style="list-style-type: none">1. Keep the air flow inlet and outlet clear or remove heat sources, charging will be enabled after cooling down.2. Maloperation of over temperature protection or devices over temperature. Please contact your dealer.
012241 ↓ 012244	External network disconnected	<ol style="list-style-type: none">1. Code scanning or app authorize application are unavailable for the moment, please change to RFID or other authorizations.2. Please contact network management staff for network inspection.
012251	Emergency switch is pressed	<ol style="list-style-type: none">1. Please release the emergency switch by rotating, charging will be enabled after warning code is removed. (Meanwhile, if it shows service page, please rotating back the switch, turn off and restart the charger)2. Please contact your dealer or turn off and restart the charger.
012252	The cabinet door has been opened	<ol style="list-style-type: none">1. Please close the cabinet door, charging will be enabled after warning code is removed.2. Door open sensor is shifted, please screw the sensor on the fixed position.3. Maloperation of door open sensor, please contact your dealer for further instruction.
012304	Communication error between power and charging gun cabinet	<ol style="list-style-type: none">1. Please make sure the ethernet cable connection between cabinets to be reliable.2. If there is no green light solid on power cabinet, please reset it.3. Please contact your dealer for further instruction.



4.3.5 (013-XXX) Troubleshooting-Message Code from Charger

Code 013-XXX contains setup, maintenance, or reference hint messages, generally there is no impact on charging. Please charging with general process and contact your dealer.

4.3.6 (023-XXX) Troubleshooting - Message Code from EV

023-XXX contains messages from EV, it means communication or charging procedure error, these errors cause charging or cable unplug cannot be proceeded. Please refer to your EV manual for charging setup or backup procedure, then eliminate fault status by following steps, or contact charger management staff.

- 1) Unplug the charging cable and wait for 5 more seconds. Plug the charging cable completely with a “clicking” sound and try the charging procedure again.
- 2) Unplug the charging cable, try with the other one or charger.
- 3) Unplug the charging cable, drive the EV away for few meters / feet and return, stop the EV, unplug the key, and try again.
- 4) After unplugging the charging cable, check the EV whether charging mode and time limit have been enabled.
- 5) If the charging process cannot be started and EV meter or charging indicator shows abnormal status or error messages, please follow your EV user manual for troubleshooting.
- 6) After unplugging the charging cable, contact management staff to turn off restart the charger and try again.
- 7) If charging terminated but the charging cable cannot be unplugged, please follow the EV user manual, press release button (on EV or remote controller) or manual unlock switch. If all these methods are unavailable, please contact management staff to turn off and restart the charger.



Status Code	Conditions	Troubleshooting methods
23758	EV side feedback code procedure error	<ol style="list-style-type: none"> 1. Please unplug the charging cable, release EV side charging limit, and try again. 2. Please follow step 1~7 for troubleshooting.
23809	Charger missed the first message from EV	<ol style="list-style-type: none"> 1. Charging cable is not locked by EV side, please unplug, and plug the charging cable completely with a "clicking" sound. 2. Please follow step 1~7 for trouble shooting
23814	EV side hand shaking feedback incorrect	<ol style="list-style-type: none"> 1. Please unplug the charging cable, restart BMS on EV side, and try again. 2. Please follow step 1~7 for troubleshooting.
23844	EV side V2G communication time out	<ol style="list-style-type: none"> 1. Please unplug the charging cable, restart BMS on EV side, and try again. 2. Please follow step 1~7 for troubleshooting.
23847	Charging cable insulation test time out	<ol style="list-style-type: none"> 1. Please unplug the charging cable and try again. 2. Please unplug the charging cable, restart the charger, and try again.
23889	Noise interference or charging terminated from EV side causes control guide status error	<ol style="list-style-type: none"> 1. Please unplug the charging cable, restart BMS on EV side, and try again. 2. Please follow step 1~7 for troubleshooting.
23891	Charger not ready	<ol style="list-style-type: none"> 1. Please unplug the charging cable, wait for 5 more seconds, and try again. 2. Please unplug the charging cable, restart the charger, and try again.
23983	Charging terminated by unknown request from	<ol style="list-style-type: none"> 1. Check whether charging target or time is limited. 2. Follow the EV operating indication for troubleshooting. 3. Please unplug the charging cable, restart BMS on EV side, and try again.



4.3.7 (033-XXX) Troubleshooting-Message Code from Charger Network

033-XXX contains messages from charger control server which is running intelligent remote control. Please follow the remote procedure or contact management staff to arrange for charging.

Status Code	Conditions	Troubleshooting methods
033900 033901 033902	Back-End disconnected for the moment	<ol style="list-style-type: none">1. Code scanning and app authorization is unavailable for the moment, please change to RFID or others authorization.2. Please contact management staff to check Back-End server connectivity.3. If the connection cannot be restored after router or AP restart, please restart the main/sub cabinets.4. If the connection cannot be restored after main/ sub cabinet restart, please turn off the whole charger and restart.5. Please contact your dealer.
033903	Charging started by remote control	<ol style="list-style-type: none">1. Remote authorization passed, please plug in the charging cable for charging.2. Contact management staff for further instructions.
033904	Charging stopped by remote control	<ol style="list-style-type: none">1. Charging meets setup time, Watt-Hour or amount, charging terminated by remote control.2. Contact management staff for further instructions.
033905	Restart by remote control	<ol style="list-style-type: none">1. Charger reset and maintain process by remote control, charging terminated.2. Contact management staff for further instructions.



4.4 Status Codes

*For latest status code, please visit our website.

(V0.48)

Status Code	Description
011001	CHAdEMO output fuse blew
011002	CCS output fuse blew
011003	GB output fuse blew
011004	RCD/CCID self-test fail
011005	AC input contactor 1 welding
011006	AC input contactor 1 driving fault
011007	AC input contactor 2 welding
011008	AC input contactor 2 driving fault
011009	AC output relay welding
011010	AC output relay driving fault
011011	CHAdEMO output relay welding
011012	CHAdEMO output relay driving fault
011013	CCS output relay welding
011014	CCS output relay driving fault
011015	GB output relay welding
011016	GB output relay driving fault
011017	AC connector temperature sensor broken
011018	CHAdEMO connector temperature sensor broken
011019	CCS connector temperature sensor broken
011020	GB connector temperature sensor broken
011021	WiFi module broken
011022	3G/4G module broken
011023	Aux. power module broken
011024	Relay control module /smart box broken
011025	CHAdEMO connector lock fail
011026	GB connector lock fail
011027	AC connector lock fail
011028	CHAdEMO module broken
011029	CCS module broken



Status Code	Description
011030	GBT module broken
011031	PSU module broken
011032	RCD/CCID module broken
011033	Maximum Output Current setup error
011034	Shutter fault
011035	Ble module broken
011036	Rotary switch fault
011037	CCS liquid chiller water level fault
011038	Chiller temperature sensor broken
011039	Parallel relay welding
011040	Parallel output relay driving fault
012200	System L1 input OVP
012201	System L2 input OVP
012202	System L3 input OVP
012203	System L1 input UVP
012204	System L2 input UVP
012205	System L3 input UVP
012206	PSU L1 input OVP
012207	PSU L2 input OVP
012208	PSU L3 input OVP
012209	PSU L1 input UVP
012210	PSU L2 input UVP
012211	PSU L3 input UVP
012212	System L1 input drop
012213	System L2 input drop
012214	System L3 input drop
012215	System AC output OVP
012216	System AC L1 output OCP
012217	System CHAdeMO output OVP
012218	System CHAdeMO output OCP
012219	System CCS output OVP
012220	System CCS output OCP



Status Code	Description
012221	System GB output OVP
012222	System GB output OCP
012223	System ambient/inlet OTP
012224	System critical point OTP
012225	PSU ambient/inlet OTP
012226	PSU critical point OTP
012227	Aux. power module OTP
012228	Relay board/smart box OTP
012229	CHAdEMO connector OTP
012230	CCS connector OTP
012231	GB connector OTP
012232	AC connector OTP
012233	RCD/CCID trip
012234	CHAdEMO GFD trip
012235	CCS GFD trip
012236	GB GFD trip
012237	SPD trip
012238	Main power breaker trip
012239	Aux. power breaker trip
012240	PSU communication fail
012241	WiFi module communication fail
012242	3G/4G module communication fail
012243	RFID module communication fail
012244	Bluetooth module communication fail
012245	LCM module communication fail
012246	Aux. power module communication fail
012247	Relay control board/smart box communication fail
012248	CCS module communication fail
012249	CHAdEMO module communication fail
012250	GBT module communication fail
012251	Emergency stop
012252	Door open



Status Code	Description
012253	System fan decay
012254	Fail to create share memory
012255	CSU initialization failed
012256	AC Ground Fault
012257	MCU self-test Fault
012258	Relay self-test Fault
012259	CHAdEMO groundfault detection timeout (GFD)
012260	CCS groundfault detection timeout (GFD)
012261	GB groundfault detection timeout (GFD)
012262	System AC L1 output Circuit Short
012263	PSU Duplicate ID
012264	PSU Output Short Circuit
012265	PSU Discharge Abnormal
012266	PSU Dc Side ShutDown
012267	PSU Failure Alarm
012268	PSU Protection Alarm
012269	PSU FanFailure Alarm
012270	PSU Input UVP
012271	PSU Input OVP
012272	PSU WalkIn State
012273	PSU Power Limited State
012274	PSU Id Repeat
012275	PSU Severe Uneven Current
012276	PSU Three Phase Input Inadequate
012277	PSU Three Phase Onput Imbalance
012278	PSU Ffc Side ShutDown
012279	NO PSU Resource
012280	Self test Failed due to communication of Relayboard failure
012281	Self test Failed due to communication of Fanboard failure
012282	Self test Failed due to communication of Primary failure
012283	Self test Failed due to communication of Chademoboard failure
012284	Self test Failed due to communication of CCSboard failure



Status Code	Description
012285	Self test Failed due to AC Contact failure
012286	Self test Failed due to communication of PSU failure
012287	Self test Failed due to Model name is none match
012288	CCS output UVP
012289	Chademo output UVP
012290	GBT output UVP
012291	Self test Failed due to communication of GBTboard failure
012292	Self test Failed due to communication of AC failure
012293	Self test Failed due to communication of Ledboard failure
012294	AC input ovp
012295	AC input uvp
012296	CHAdEMO groundfault detection - warning
012297	CCS groundfault detection - warning
012298	GB groundfault detection - warning
012299	System AC L2 output OCP
012300	System AC L3 output OCP
012301	System AC L2 output Circuit Short
012302	System AC L3 output Circuit Short
012303	CCS liquid chiller water level warning
012304	disconnected from power cabinet
012305	Meter communication timeout
012306	The dip switch of the PSU may be incorrect
012307	Psu Fault : Fuse Burn-Out
012308	Psu Fault : Pfc And Dcdc Communication Fault
012309	Psu Fault : Bus Voltage Unbalance
012310	Psu Fault : Bus Over Voltage
012311	Psu Fault : Bus Voltage Abnormal
012312	Psu Fault : Bus Under Voltage
012313	Psu Fault : Input Phase Loss
012314	Psu Fault : Fan Full Speed
012315	Psu Fault : Temperature Power Limit
012316	Psu Fault : Ac Power Limit



Status Code	Description
012317	Psu Fault : Dcdc Eeprom Fault
012318	Psu Fault : Pfc Eeprom Fault
012319	Psu Dcdc Over Voltage
012320	System CHAdeMO output UCP
012321	System CCS output UCP
012322	System GBT output UCP
012323	System Chiller output OTP
012324	Connector 1 detects abnormal voltage on the output line
012325	Connector 2 detects abnormal voltage on the output line
012326	System task is lost
012327	System DC input ovp
012328	System DC input uvp
012329	Psu Fault : Psu Can Communication Fault
012330	Psu Fault : Psu Dc to Dc OTP
012331	Psu Fault : Psu Dc to Dc OVP
012332	Chiller Tube OTP
012333	Psu Fault : DC input ovp (Phase OVP)
012343	Tilt sensor self-test failed
012344	Meter IC communication timeout
012345	Pilot negative error
012346	Psu Communication error with CSU
012347	AC: Local power sharing communication error (Slave disconnect from Master)
012348	Chiller Alarm Failure
012352	Payment system communication timeout
012353	Meter Slave Los Link
012354	Meter Sync Time Error
012355	Meter Start Transaction Error
012356	Meter Stop Transaction Error
012357	Meter Get Transaction Ocmf Error
013600	Normal stop charging by user
013601	Charging Time's up



Status Code	Description
013602	Replace system air filter
013603	Reach to CHAdeMO max. plugging times.
013604	Reach to CCS max. plugging times.
013605	Reach to GB max. plugging times.
013606	Reach to AC max. plugging times.
013607	CSU fimrware update fail
013608	CHAdeMO Module fimrware update fail
013609	CCS Module fimrware update fail
013610	GB Module fimrware update fail
013611	Aux. power module fimrware update fail
013612	Relay control module fimrware update fail
013613	LCM module fimrware update fail
013614	Bluetooth module fimrware update fail
013615	WiFi module fimrware update fail
013616	3G/4G module fimrware update fail
013617	SMR fimrware update fail
013618	RFID module fimrware update fail
013619	configured by USB flash drive
013620	configured by backend
013621	configured by webage
013622	disconnected from Internet through Ethernet
013623	disconnected from Internet through WiFi
013624	disconnected from Internet through 3G/4G
013625	disconnected from AP through WiFi
013626	disconnected from APN through 3G/4G
013627	WiFi disabled (separated charger only)
013628	4G disabled (separated charger only)
013629	PSU quantity not match
023700	CHAdeMO EV communication Fail
023701	CCS EV communication Fail
023702	GB EV communication Fail
023703	AC: pilot fault



Status Code	Description
023704	CHAdEMO: battery malfunction
023705	CHAdEMO: no charging permission
023706	CHAdEMO: battery incompatibility
023707	CHAdEMO: battery OVP
023708	CHAdEMO: battery UVP
023709	CHAdEMO: battery OTP
023710	CHAdEMO: battery current difference
023711	CHAdEMO: battery voltage difference
023712	CHAdEMO: shift position
023713	CHAdEMO: battery other fault
023714	CHAdEMO: charging system error
023715	CHAdEMO: ev normal stop
023716	CHAdEMO: connector temperature sensor broken
023717	CHAdEMO: connector lock fail
023718	CHAdEMO: d1 on no receive
023719	CHAdEMO: bms k to j on timeout
023720	CHAdEMO: bms charge allow timeout
023721	CHAdEMO: wait groundfault timeout (Output short circuit)
023722	CHAdEMO: bms ev relay on timeout
023723	CHAdEMO: bms req current timeout
023724	CHAdEMO: bms k to j off timeout
023725	CHAdEMO: bms ev relay off timeout
023726	CHAdEMO: adc more than 10v
023727	CHAdEMO: adc more than 20v
023728	CHAdEMO: bms charge before stop
023729	CHAdEMO: charger get normal stop cmd
023730	CHAdEMO: charger get emergency stop cmd
023731	CHAdEMO: isolation result fail
023732	CHAdEMO: mother board miss link
023733	CHAdEMO: output voltage more than limit
023734	CHAdEMO: req current more than limit
023735	CHAdEMO: re capability bms eqr current exceed



Status Code	Description
023736	CHAdEMO: charge remaining count done
023737	CCS_EVCC_EVErrorCode_FAILED_RESSTemperatureInhibit
023738	CCS_EVCC_EVErrorCode_FAILED_EVShiftPosition
023739	CCS_EVCC_EVErrorCode_FAILED_ChargerConnectorLockFault
023740	CCS_EVCC_EVErrorCode_FAILED_EVRESSMalfunction
023741	CCS_EVCC_EVErrorCode_FAILED_ChargingCurrentdifferential
023742	CCS_EVCC_EVErrorCode_FAILED_ChargingVoltageOutOfRange
023743	CCS_EVCC_EVErrorCode_FAILED_ChargingSystemIncompatibility
023744	CCS_EVCC_EVErrorCode_FAILED_EmergencyEvent
023745	CCS_EVCC_EVErrorCode_FAILED_Breaker
023746	CCS_EVCC_EVErrorCode_FAILED_NoData
023747	CCS_EVCC_EVErrorCode_FAILED_reserved_by_DIN_A
023748	CCS_EVCC_EVErrorCode_FAILED_reserved_by_DIN_B
023749	CCS_EVCC_EVErrorCode_FAILED_reserved_by_DIN_C
023750	CCS_EVCC_EVErrorCode_FAILED_reserved_by_ISO_1
023751	CCS_EVCC_EVErrorCode_FAILED_reserved_by_ISO_2
023752	CCS_EVCC_EVErrorCode_FAILED_reserved_by_ISO_3
023753	CCS_EVCC_EVErrorCode_FAILED_reserved_by_OEM_1
023754	CCS_EVCC_EVErrorCode_FAILED_reserved_by_OEM_2
023755	CCS_EVCC_EVErrorCode_FAILED_reserved_by_OEM_3
023756	CCS_EVCC_EVErrorCode_FAILED_reserved_by_OEM_4
023757	CCS_EVCC_EVErrorCode_FAILED_reserved_by_OEM_5
023758	CCS_SECC_ResponseCode_FAILED_SequenceError
023759	CCS_SECC_ResponseCode_FAILED_SignatureError
023760	CCS_SECC_ResponseCode_FAILED_UnknownSession
023761	CCS_SECC_ResponseCode_FAILED_ServiceIDInvalid
023762	CCS_SECC_ResponseCode_FAILED_Payment SelectionInvalid
023763	CCS_SECC_ResponseCode_FAILED_IdentificationSelectionInvalid
023764	CCS_SECC_ResponseCode_FAILED_ServiceSelectionInvalid
023765	CCS_SECC_ResponseCode_FAILED_CertificateExpired
023766	CCS_SECC_ResponseCode_FAILED_CertificateNotYetValid
023767	CCS_SECC_ResponseCode_FAILED_CertificateRevoked



Status Code	Description
023768	CCS_SECC_ResponseCode_FAILED_NoCertificateAvailable
023769	CCS_SECC_ResponseCode_FAILED_CertChainError
023770	CCS_SECC_ResponseCode_FAILED_CertValidationError
023771	CCS_SECC_ResponseCode_FAILED_CertVerificationError
023772	CCS_SECC_ResponseCode_FAILED_ContractCanceled
023773	CCS_SECC_ResponseCode_FAILED_ChallengeInvalid
023774	CCS_SECC_ResponseCode_FAILED_WrongEnergyTransferMode
023775	CCS_SECC_ResponseCode_FAILED_WrongChargeParameter
023776	CCS_SECC_ResponseCode_FAILED_ChargingProfileInvalid
023777	CCS_SECC_ResponseCode_FAILED_TariffSelectionInvalid
023778	CCS_SECC_ResponseCode_FAILED_EVSEPresentVoltageTooLow
023779	CCS_SECC_ResponseCode_FAILED_PowerDeliveryNotApplied
023780	CCS_SECC_ResponseCode_FAILED_MeteringSignatureNotValid
023781	CCS_SECC_ResponseCode_FAILED_NoChargeServiceSelected
023782	CCS_SECC_ResponseCode_FAILED_ContactorError
023783	CCS_SECC_ResponseCode_FAILED_CertificateNotAllowedAtThisEVSE
023784	CCS_SECC_ResponseCode_FAILED_GAChargeStop
023785	CCS_SECC_ResponseCode_FAILED_AlignmentError
023786	CCS_SECC_ResponseCode_FAILED_ACDError
023787	CCS_SECC_ResponseCode_FAILED_AssociationError
023788	CCS_SECC_ResponseCode_FAILED_EVSEChargeAbort
023789	CCS_SECC_ResponseCode_FAILED_NoSupportedApp-Protocol
023790	CCS_SECC_ResponseCode_FAILED_ContractNotAccepted
023791	CCS_SECC_ResponseCode_FAILED_MOUnknown
023792	CCS_SECC_ResponseCode_FAILED_OEM_Prov_CertificateRevoke
023793	CCS_SECC_ResponseCode_FAILED_OEM_SubCA1_CertificateRevoked
023794	CCS_SECC_ResponseCode_FAILED_OEM_SubCA2_CertificateRevoked
023795	CCS_SECC_ResponseCode_FAILED_OEM_RootCA_CertificateRevoked
023796	CCS_SECC_ResponseCode_FAILED_MO_Prov_CertificateRevoked



Status Code	Description
023797	CCS_SECC_ResponseCode_FAILED_MO_SubCA1_CertificateRevoked
023798	CCS_SECC_ResponseCode_FAILED_MO_SubCA2_CertificateRevoked
023799	CCS_SECC_ResponseCode_FAILED_MO_RootCA_CertificateRevoked
023800	CCS_SECC_ResponseCode_FAILED_CPS_Prov_CertificateRevoked
023801	CCS_SECC_ResponseCode_FAILED_CPS_SubCA1_CertificateRevoked
023802	CCS_SECC_ResponseCode_FAILED_CPS_SubCA2_CertificateRevoked
023803	CCS_SECC_ResponseCode_FAILED_CPS_RootCA_CertificateRevoked
023804	CCS_SECC_ResponseCode_FAILED_reserved_1
023805	CCS_SECC_ResponseCode_FAILED_reserved_2
023806	CCS_SECC_ResponseCode_FAILED_reserved_3
023807	CCS_SECC_ResponseCode_FAILED_reserved_4
023808	CCS_SECC_ResponseCode_FAILED_reserved_5
023809	CCS_SECC_TIMEOUT_SLAC_TT_EVSE_SLAC_init
023810	CCS_SECC_TIMEOUT_SLAC_TP_match_response
023811	CCS_SECC_TIMEOUT_CM_START_ATTEN_CHAR_IND
023812	CCS_SECC_TIMEOUT_SLAC_TT_EVSE_match_MNBC
023813	CCS_SECC_TIMEOUT_SLAC_TP_EVSE_avg_atten_calc
023814	CCS_SECC_TIMEOUT_SLAC_CM_ATTEN_CHAR_RSP
023815	CCS_SECC_TIMEOUT_SLAC_CM_VALIDATE_REQ_1ST_CM_SLAC_MATCH_REQ
023816	CCS_SECC_TIMEOUT_SLAC_TT_EVSE_assoc_session
023817	CCS_SECC_TIMEOUT_SLAC_TT_EVSE_vald_toggle
023818	CCS_SECC_TIMEOUT_SLAC_CM_MNBC_SOUND_IND
023819	CCS_SECC_TIMEOUT_SLAC_CM_VALIDATE_REQ_2ND_CM_SLAC_MATCH_REQ
023820	CCS_SECC_TIMEOUT_SLAC_reserved_3
023821	CCS_SECC_TIMEOUT_SLAC_reserved_4
023822	CCS_SECC_TIMEOUT_SLAC_reserved_5



Status Code	Description
023823	CCS_SECC_TIMEOUT_SLACC_SDP_UDP_TT_match_join
023824	CCS_SECC_TIMEOUT_SLACC_SDP_TCP_TT_match_join
023825	CCS_SECC_TIMEOUT_SLACC_SDP_TP_amp_map_exchange
023826	CCS_SECC_TIMEOUT_SLACC_SDP_TP_link_ready_notification
023827	CCS_SECC_TIMEOUT_SLACC_SDP_reserved_1
023828	CCS_SECC_TIMEOUT_SLACC_SDP_reserved_2
023829	CCS_SECC_TIMEOUT_SLACC_SDP_reserved_3
023830	CCS_SECC_TIMEOUT_SLACC_SDP_reserved_4
023831	CCS_SECC_TIMEOUT_SLACC_SDP_reserved_5
023832	CCS_SECC_TIMEOUT_V2G_Msg_Performance_Time_SupportedAppProtocolRes
023833	CCS_SECC_TIMEOUT_V2G_Msg_Performance_Time_SessionSetupRes
023834	CCS_SECC_TIMEOUT_V2G_Msg_Performance_Time_ServiceDiscoveryRes
023835	CCS_SECC_TIMEOUT_V2G_Msg_Performance_Time_ServicePaymentSelectionRes
023836	CCS_SECC_TIMEOUT_V2G_Msg_Performance_Time_ContractAuthenticationRes
023837	CCS_SECC_TIMEOUT_V2G_Msg_Performance_Time_ChargeParameterDiscoveryRes
023838	CCS_SECC_TIMEOUT_V2G_Msg_Performance_Time_PowerDeliveryRes
023839	CCS_SECC_TIMEOUT_V2G_Msg_Performance_Time_CableCheckRes
023840	CCS_SECC_TIMEOUT_V2G_Msg_Performance_Time_PreChargeRes
023841	CCS_SECC_TIMEOUT_V2G_Msg_Performance_Time_CurrentDemandRes
023842	CCS_SECC_TIMEOUT_V2G_Msg_Performance_Time_WeldingDetectionRes
023843	CCS_SECC_TIMEOUT_V2G_Msg_Performance_Time_SessionStopRes
023844	CCS_SECC_TIMEOUT_V2G_Sequence_Time
023845	CCS_SECC_TIMEOUT_V2G_ReadyToCharge_Performance_Time



Status Code	Description
023846	CCS_SECC_TIMEOUT_V2G_CommunicationSetup_Performance_Time
023847	CCS_SECC_TIMEOUT_V2G_CableCheck_Performance_Time (Output short circuit)
023848	CCS_SECC_TIMEOUT_V2G_CPState_Detection_Time
023849	CCS_SECC_TIMEOUT_V2G_CPOscillator_Retain_Time
023850	CCS_SECC_TIMEOUT_V2G_PreCharge_Performance_Time
023851	CCS_SECC_TIMEOUT_V2G_reserved_2
023852	CCS_SECC_TIMEOUT_V2G_reserved_3
023853	CCS_SECC_TIMEOUT_V2G_reserved_4
023854	CCS_SECC_TIMEOUT_V2G_reserved_5
023855	CCS_CAN_TIMEOUT_TP_GET_EV_TARGET_INFO
023856	CCS_CAN_TIMEOUT_TT_GET_EV_TARGET_INFO
023857	CCS_CAN_TIMEOUT_TP_GET_EV_BATTERY_INFO
023858	CCS_CAN_TIMEOUT_TT_GET_EV_BATTERY_INFO
023859	CCS_CAN_TIMEOUT_TP_EV_STOP_EVENT
023860	CCS_CAN_TIMEOUT_TT_EV_STOP_EVENT
023861	CCS_CAN_TIMEOUT_TP_EVSE_STOP_EVENT
023862	CCS_CAN_TIMEOUT_TT_EVSE_STOP_EVENT
023863	CCS_CAN_TIMEOUT_TP_GET_MISC_INFO
023864	CCS_CAN_TIMEOUT_TT_GET_MISC_INFO
023865	CCS_CAN_TIMEOUT_TP_DOWNLOAD_REQUEST
023866	CCS_CAN_TIMEOUT_TT_DOWNLOAD_REQUEST
023867	CCS_CAN_TIMEOUT_TP_START_BLOCK_TRANSFER
023868	CCS_CAN_TIMEOUT_TT_START_BLOCK_TRANSFER
023869	CCS_CAN_TIMEOUT_TP_DATA_TRANSFER
023870	CCS_CAN_TIMEOUT_TT_DATA_TRANSFER
023871	CCS_CAN_TIMEOUT_TP_DOWNLOAD_FINISH
023872	CCS_CAN_TIMEOUT_TT_DOWNLOAD_FINISH
023873	CCS_CAN_TIMEOUT_TP_ISOLATION_STATUS
023874	CCS_CAN_TIMEOUT_TT_ISOLATION_STATUS
023875	CCS_CAN_TIMEOUT_TP_CONNECTOR_INFO



Status Code	Description
023876	CCS_CAN_TIMEOUT_TT_CONNECTOR_INFO
023877	CCS_CAN_TIMEOUT_TT_RTC_INFO
023878	CCS_CAN_TIMEOUT_TP_RTC_INFO
023879	CCS_CAN_TIMEOUT_TP_EVSE_PRECHARGE_INFO
023880	CCS_CAN_TIMEOUT_TT_EVSE_PRECHARGE_INFO
023881	CCS_CAN_TIMEOUT_MSG_Sequence
023882	CCS_CAN_MSG_Unrecognized_CMD_ID
023883	CCS_SECC_DIN_Msg_Decode_Error
023884	CCS_SECC_DIN_Msg_Encode_Error
023885	CCS_SECC_ISO1_Msg_Decode_Error
023886	CCS_SECC_ISO1_Msg_Encode_Error
023887	CCS_SECC_ISO2_Msg_Decode_Error
023888	CCS_SECC_ISO2_Msg_Encode_Error
023889	CCS_SECC_CP_State_Error
023890	CCS_SECC_Unexpected_60V_Before_Charing_Error
023891	CCS_SECC_Not_Ready_For_Charging
023892	CCS_SECC_TIMEOUT_QCA7000_COMM (The firmware code of QCA7000 may not be installed, yet)
023893	CCS_SECC_FAIL_QCA7000_SETKEY
023900	GBT_LOS_CC1
023901	GBT_CONNECTOR_LOCK_FAIL
023902	GBT_BATTERY_INCOMPATIBLE
023903	GBT_BMS_BROAA_TIMEOUT
023904	GBT_CSU_PRECHARGE_TIMEOUT
023905	GBT_BMS_PRESENT_VOLTAGE_FAULT
023906	GBT_BMS_VOLTAGE_OVER_RANGE
023907	GBT_BSM_CHARGE_ALLOW_00_10MIN_COUUNTDONE
023908	GBT_WAIT_GROUNDFULT_TIMEOUT
023909	GBT_ADC_MORE_THAN_10V
023910	GBT_ADC_MORE_THAN_60V
023911	GBT_CHARGER_GET_NORMAL_STOP_CMD
023912	GBT_CHARGER_GET_EMERGENCY_STOP_CMD



Status Code	Description
023913	GBT_ISOLATION_RESULT_FAIL
023914	GBT_MOTHER_BOARD_MISS_LINK
023915	GBT_OUTPUT_VOLTAGE_MORE_THAN_LIMIT
023916	GBT_REQ_CURRENT_MORE_THAN_LIMIT
023917	GBT_OUTPUT_VOLTAGE_MORE_THAN_10_PERCENT
023918	GBT_OUTPUT_VOLTAGE_DIFF_BCS_5_PERCENT
023919	GBT_STOP_ADC_MORE_THAN_10V
023920	ERROR_CODE_GBT_BMS_BROAA_NO_VOLTAGE_TIMEOUT
023921	ERROR_CODE_GBT_BMS_BROAA_TO_BRO00_ERROR
023930	GBT_CEM_BHM_TIMEOUT
023931	GBT_CEM_BRM_TIMEOUT
023932	GBT_CEM_BCP_TIMEOUT
023933	GBT_CEM_BRO_TIMEOUT
023934	GBT_CEM_BCL_TIMEOUT
023935	GBT_CEM_BCS_TIMEOUT
023936	GBT_CEM_BSM_TIMEOUT
023937	GBT_CEM_BST_TIMEOUT
023938	GBT_CEM_BSD_TIMEOUT
023939	GBT_CEM_BEM_OTHER_TIMEOUT
023940	GBT_BEM_CRM_TIMEOUT
023941	GBT_BEM_CRMAA_TIMEOUT
023942	GBT_BEM_CTS_CML_TIMEOUT
023943	GBT_BEM_CRO_TIMEOUT
023944	GBT_BEM_CCS_TIMEOUT
023945	GBT_BEM_CST_TIMEOUT
023946	GBT_BEM_CSD_TIMEOUT
023947	GBT_BEM_BEM_OTHER_TIMEOUT
023950	GBT_BST_SOC_GOAL
023951	GBT_BST_TOTAL_VOLTAGE_GOAL
023952	GBT_BST_CELL_VOLTAGE_GOAL
023953	GBT_BST_GET_CST
023954	GBT_BST_ISOLATION



Status Code	Description
023955	GBT_BST_OUTPUT_CONNECTOR_OTP
023956	GBT_BST_COMPONENT
023957	GBT_BST_CHARGE_CONNECTOR
023958	GBT_BST_OTP
023959	GBT_BST_OTHER
023960	GBT_BST_HIGH_V
023961	GBT_BST_CC2
023962	GBT_BST_CURRENT
023963	GBT_BST_VOLTAGE
023964	GBT_GET_BST_NO_REASON
023970	GBT_BSM_CELL_OVER_VOLTAGE
023971	GBT_BSM_CELL_UNDER_VOLTAGE
023972	GBT_BSM_OVER_SOC
023973	GBT_BSM_UNDER_SOC
023974	GBT_BSM_CURRENT
023975	GBT_BSM_TEMPERATURE
023976	GBT_BSM_ISOLATE
023977	GBT_BSM_OUTPUT_CONNECTOR
023979	CCS_EV full charging
023980	ERROR_CODE_CHADEMO_BMS_CHARGE_ALLOW_ERROR
023981	ERROR_CODE_CHADEMO_OUTPUT_VOLTAGE_MORE_THAN_10_PERCENT
023982	ERROR_CODE_CHADEMO_ADC_LESS_THAN_10V
023983	CCS_STOP by EV with unknow reason
023984	STOP by EVSE condition (Config or OCPP)
033900	disconnected from backend through Ethernet
033901	disconnected from backend through WiFi
033902	disconnected from backend through 3G/4G
033903	Remote start charging by backend
033904	Remote stop charging by backend
033905	Remote reset by backend
041004	RCD/CCID self-test fail



Status Code	Description
041005	AC input contactor 1 welding
041006	AC input contactor 1 driving fault
041007	AC input contactor 2 welding
041008	AC input contactor 2 driving fault
041009	AC output relay welding
041010	AC output relay driving fault
041017	AC connector temperature sensor broken
041021	WiFi module broken
041022	3G/4G module broken
041023	Aux. power module broken
041024	Relay control module /smart box broken
041031	PSU module broken
041032	RCD/CCID module broken
041033	Maximum Output Current setup error
041034	Shutter fault
041035	Ble module broken
041036	Rotary switch fault
042200	System L1 input OVP
042201	System L2 input OVP
042202	System L3 input OVP
042203	System L1 input UVP
042204	System L2 input UVP
042205	System L3 input UVP
042206	PSU L1 input OVP
042207	PSU L2 input OVP
042208	PSU L3 input OVP
042209	PSU L1 input UVP
042210	PSU L2 input UVP
042211	PSU L3 input UVP
042212	System L1 input drop
042213	System L2 input drop
042214	System L3 input drop



Status Code	Description
042223	System ambient/inlet OTP
042224	System critical point OTP
042225	PSU ambient/inlet OTP
042226	PSU critical point OTP
042227	Aux. power module OTP
042228	Relay board/smart box OTP
042232	AC connector OTP
042233	RCD/CCID trip
042237	SPD trip
042238	Main power breaker trip
042239	Aux. power breaker trip
042240	PSU communication fail
042241	WiFi module communication fail
042242	3G/4G module communication fail
042244	Bluetooth module communication fail
042246	Aux. power module communication fail
042247	Relay control board/smart box communication fail
042251	Emergency stop
042252	Door open
042253	System fan decay
042254	Fail to create share memory
042255	CSU initialization failed
042257	MCU self-test Fault
042258	Relay self-test Fault
042262	System AC L1 output Circuit Short
042263	PSU Duplicate ID
042264	Psu Fault : Output Short Circuit
042265	PSU Discharge Abnormal
042266	PSU Dc Side ShutDown
042267	PSU Failure Alarm
042268	PSU Protection Alarm
042269	Psu Fault : Fan Fault



Status Code	Description
042270	PSU Input UVP
042271	PSU Input OVP
042272	PSU WalkIn State
042273	Psu Fault : Power Limited State
042274	Psu Fault : Id Repeat
042275	Psu Fault : Severe Uneven Current
042276	PSU Three Phase Input Inadequate
042277	PSU Three Phase Onput Imbalance
042278	PSU Ffc Side ShutDown
042279	NO PSU Resource
042280	Self test Failed due to communication of Relayboard failure
042281	Self test Failed due to communication of Fanboard failure
042282	Self test Failed due to communication of Primary failure
042283	Self test Failed due to communication of Chademoboard failure
042284	Self test Failed due to communication of CCSboard failure
042285	Self test Failed due to AC Contact failure
042286	Self test Failed due to communication of PSU failure
042287	Self test Failed due to Model name is none match
042291	Self test Failed due to communication of GBTboard failure
042292	Self test Failed due to communication of AC failure
042293	Self test Failed due to communication of Ledboard failure
042294	AC input ovp
042295	AC input uvp
042299	System AC L2 output OCP
042300	System AC L3 output OCP
042301	System AC L2 output Circuit Short
042302	System AC L3 output Circuit Short
042304	disconnected from dispenser
042305	Meter communication timeout
042306	The dip switch of the PSU may be incorrect
042307	Psu Fuse Burn-Out
042308	Psu Pfc And Dcdc Communication Fault



Status Code	Description
042309	Psu Bus Voltage Unbalance
042310	Psu Bus Over Voltage
042311	Psu Bus Voltage Abnormal
042312	Psu Bus Under Voltage
042313	Psu Input Phase Loss
042314	Psu Fan Full Speed
042315	Psu Temperature Power Limit
042316	Psu Ac Power Limit
042317	Psu Dcdc Eeprom Fault
042318	Psu Pfc Eeprom Fault
042319	Psu Dcdc Over Voltage
042326	System task is lost
042327	DC input ovp
042328	DC input uvp
043600	Normal stop charging by user
043601	Charging Time's up
043602	Replace system air filter
043607	CSU fimrware update fail
043611	Aux. power module fimrware update fail
043612	Relay control module fimrware update fail
043614	Bluetooth module fimrware update fail
043615	WiFi module fimrware update fail
043616	3G/4G module fimrware update fail
043617	SMR fimrware update fail
043618	RFID module fimrware update fail
043619	configured by USB flash drive
043620	configured by backend
043621	configured by webage
043622	disconnected from Internet through Ethernet
043623	disconnected from Internet through WiFi
043624	disconnected from Internet through 3G/4G
043625	disconnected from AP through WiFi



Status Code	Description
043626	disconnected from APN through 3G/4G
043627	WiFi disabled (separated charger only)
043628	4G disabled (separated charger only)
043629	PSU quantity not match



5. Maintenance

5.1 Before Maintenance

To meet NFPA-70E, OSHA 1910.333 and other Health/safety/security codes, please adhere to the notice and get the permit needed in advance as below:

- 1) Turn off power (Work de-energized whenever possible)
- 2) Lockout/Tagout (LOTO)
- 3) Live work permit (Input terminals with HV after door open)
- 4) Plan the Work/Permit To Work
- 5) Use Personal Protective Equipment (PPE)
- 6) Safe workplace condition & space

5.1.1 Maintenance Check List

Please refer to Appendix for more details.

5.2 General Maintenance

- The DC Fast Charger is cooled by forced air. Please keep charger in a ventilated location and do not block the air vents of the DC Fast Charger.
- Please clean or replace the air filters regularly to ensure the DC Fast Charger works properly.
- The housing was made of welding process and surface painting. It is necessary to keep the exterior clean all the time. It's easy to get rusty if not keeping the exterior clean especially in corrosion sensitive environment. Slightly rusty will not affect charger performance, but if charger is serious rusty during or exceed the warranty period, please contact local vendor for instruction.
- Clean the DC fast Charger at least three times a year, keep the exterior clean at all times.
- Clean the outside of the cabinet with damp cloth or wet cotton towel, only use low-pressure tap water and cleaning agents with PH level between 6 to 8.
- Do not apply high-pressure water jets.
- Do not use cleaning agents with abrasive components and do not use abrasive tools. Improper cleaning agents might spoiled coating, painting, surface, brightness and durability of all exterior parts.
- If there is water intruding into the DC Fast Charger then please cut off the power source immediately and contact the DC Fast Charger provider for repair.
- Please make sure the charging connector is returned to the holder of the charging connector after charging to prevent damage.
- If there is damage to the charging connector, charging cable or holder of the charging connector then please contact the DC Fast Charger provider.



- When using the DC Fast Charger please handle properly. Do not strike or scrape the cabinet or screen.
- If the enclosure or screen is broken, cracked, open or shows any other indication of damage then please contact the Standalone DC Fast Charger provider.



WARNING: Danger of electrical shock or injury. Turn OFF power at the panelboard or load center before working on the equipment or removing any component. Do not remove circuit protective devices or any other component until the power is turned OFF.

- Disconnect electrical power to the DC Fast Charger before any maintenance work to ensure it is separated from the supply of AC mains. Failure to do so may cause physical injury or damage to the electrical system and charging unit.

Note:

- Before switching off main breaker to begin maintenance, please record the status code number on the LCD monitor.
- After maintenance door opened or MCCB of charger turned off the charger is still hazardous. Only visual inspection can be operated.
- Maintenance of the DC Fast Charger shall be conducted only by a qualified technician.
- After opening the front door of the DC Fast Charger, turn off the main breaker and auxiliary breaker before any maintenance work.
- Replace the ventilation filter every six to twelve months.
- Please confirm the main power junctions are tightened every month, and rotate cables testing when the power off. If any main power screw is loose will be resulted in damage on charger or smoke on the connections. Please confirm screw torque requirement table.
- Charging cable maintenance: Do not twist, bend the charging cable. The metal contact should not fade or be rusty.
- Please provide the EVSE information including serial number ,model name,status code ,failure behavior and timing ,and also connect the EVSE to the Internet before remote diagnostics and upgrading.
- Inspect the charging connector, pump, cooling unit and coolant every 3 months
- Do not twist, swing, bend, drop or crush the charging cable. Never drive over it with a vehicle.

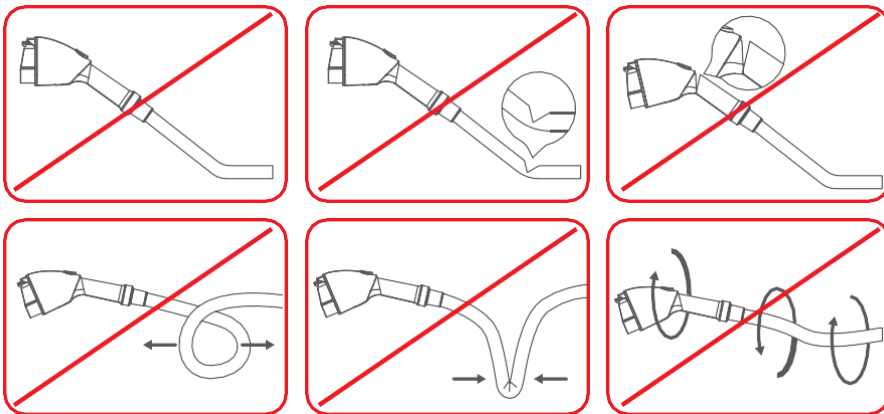

- Make sure that the minimum bending radius is not exceeded.
- After charging, place the cable immediately back into the holder of the charging station.
- Leakage or material degradation may occur if a coolant other than that specified by the manufacturer of the accessory is used.
- Pump must not be operated without coolant ; level of coolant should be keep in 100mm(3.94")~150mm(5.91").

Note: Considering the different environmental conditions, we recommend the minimum height greater than 130mm.

- The air will be concentrated in cooling system if the charger is not used for a period.
- Please exhaust the air first as instruction after setting.
- If you observe that the customer has not used it for a long time, please pay special attention.

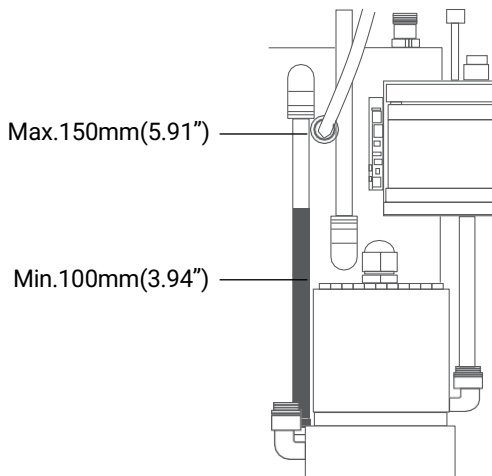

- Please carry the following inspection at specified interval for liquid cooled charging cable system

A. Recommended maintenance interval every 3 months or as needed Connector:

- Visual inspection for defects or damage.
- Check cover for scratches.
- When exchanging the cover, check for mechanical damages.
- Check the screws for secure fastening.
- Clean the outside of the connector with damp cloth.
- Clean the outside of the connector with a wet cotton towel.

Cable:

- Visual inspection for defects or damage.
- Check the charging cable for secure fastening.
- Clean the charging cable with a wet cotton towel.

Cooling Unit:

- Visual inspection for defects or damage.
- Check the cooling unit for secure fastening.
- Check the level of the coolant. (If required refill the coolant)



B. Recommended maintenance interval every 12 months Wait until the charging system has cooled down. Cable, connector and cooling unit:

- Check for firm seat.
- Visual inspection for defects or damage.
- Check the safety function.

Cooling Unit:

- Visual inspection for defects or damage.
- Check the cooling unit for secure fastening.
- Check the level of the coolant.



5.3 Replacement Kits and Accessories

The DC EVSE offers the following replacement kits and accessories.

Replacement Kit List
7-inch LCDMW Aux.
Power HLG-40H-15A
MW Aux. Power HEP-600-24A
MW Aux. Power HEP-100-12A
Control & Supervisory Unit (CSU3.1)
Surge Protection Device (SPD)
DC Fan
Air Filters
Relay
Coolant
Cooling unit
Relay board
Fan board
LED board



6. Limited Product Warranty

The warranty period of this charger is according to purchasing contract; two years typically.

Replacement and repair parts manufactured by alternative manufacturers to those on the maintenance parts are only allowed if authorized by supplier.

The housing was made of welding process and surface painting. It is necessary to keep the exterior clean all the time. It's easy to get rusty if not keeping the exterior clean especially in corrosion sensitive environment. Slightly rusty will not affect charger performance, but if charger is serious rusty during or exceed the warranty period, please contact local vendor for instruction.

Warranty Exclusions:

- Damage or rendered non-functional as a result of power surges, lightning, earthquake, fire, flood, pest damage, abuse, accident, misuse, negligence or failure to maintain the product or other event beyond supplier's reasonable control or not arising from normal operating condition.
- Cosmetic or superficial defect, dents, marks or scratches after use.
- Components which are separate from the product, ancillary equipment and consumables, such as door key, RFID card, air filter, fuse, cable, wires and connectors.
- Damage as a result of modifications, alterations or disassembling which were not pre-authorized in writing by supplier.
- Damage due to the failure to observe the applicable safety regulations governing the proper use of the product.
- Installed or operated not in strict conformance with the documentation, including without limitation, not ensuring sufficient ventilation for the product as described in supplier installation instruction.

If a defect in the product arises and valid claim is received within the warranty period, your sole and exclusive remedy will be for supplier, at its sole discretion and to extent permitted by law, to

1. Repair the defect in the product at no charge, using new or refurbished parts.
2. Exchange the product with new or refurbished product that is functionally equivalent to the original product.



Any remedy hardware product will be warranted for the remainder of the original warranty period or 90 days from delivery to the customer, whichever is longer.

In order to receive the remedy set for above, you must contact supplier during the warranty period and provide the model number, series number, proof of purchase, and date of purchase.

This warranty does not cover the damages caused by adapter usage accident or by other unauthorized operation/service.



Appendix 1 - Package List

Item	Description	No.	Remark
1	EVSE-Power Dispenser	1	
2	User Manual	1	
3	OQC Report	1	
4	RFID Card	2	
5	Key of cabinet	1	
6	Waterproof plastic bolt	4	
7	CAT6A FTP RJ45 Plug	2	
A	Cable Management	1	Optional



Appendix 2 - Maintenance Period

No.	Item	Description	0.5 year	1st year	2nd year	3rd year	4th year	5th year
1	Preventive maintenance		I	I	I	I	I	I
2	Appearance inspection	Appearance visual inspection	I	I	I	I	I	I
3	System fan	Fan clean and spinning smoothly check	I	I	I	R	I	I
4	Air filter	Air filter, air inlet and outlet clean	I	I	R	I	R	I
5	Charging cable	Appearance clean	I	I	I	R	I	I
6	PCBA	Visible section clean	--	I	I	I	I	R
7	SPD	SPD status indication check	I	I	I	I	I	R
8	DC output bolts torque	Bolts torque check	--	I	I	I	I	I
9	AC input bolts torque	Bolts torque check	--	I	I	I	I	I
10	LCD display	Display sharpness and backlight check	--	I	I	I	I	R
11	Selection button	Indication light and function check	--	I	I	I	I	R
12	RFID reader	Function check	--	I	I	I	I	R
13	Emergency stop button	Function check	--	I	I	I	I	R
14	Breaker and RCD	Function check	--	I	I	I	I	R
15	Aux power supply	No maintenance requirement	--	--	--	--	--	R
16	Coolant level	Level inspection or refilling	I	I	I	I	I	I

Note:

1. Depending on the environment, user may decide the timing of filter replacement.
2. Coolant level must be checked and refilled after liquid-cooling charging cable replacement.

I: Inspection or refilling recommended

R: Replacement recommended

--: No maintenance needed or depend on the situation



Appendix 3 - Standard Design Dispenser

This user manual also applied for standard design dispenser, the differences will only be the height of LCD screen and the ways of installing cable.

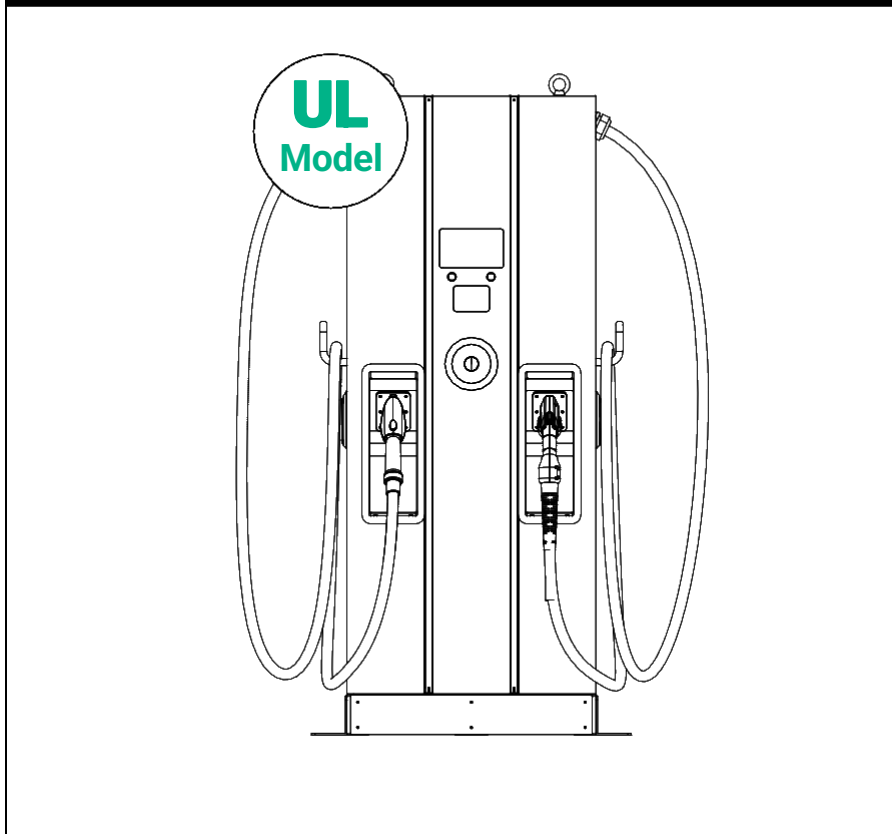



Installing Cables

Fasten the PE cable to grounding plate of cabinet; connect AC input Line cable , Neutral cable and PE cable to terminal block. Fasten DC+ and DC- cables from power cabinet to paired busbar.

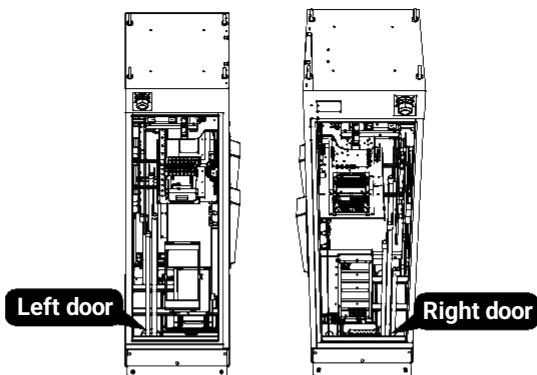

Left Door

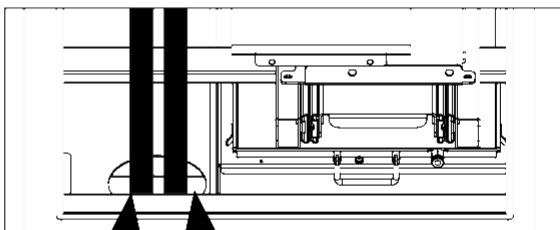

*The charging connectors installed on the EVSE may vary depending on the designated application.

Right Door

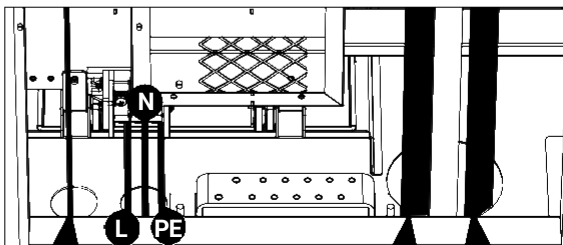

*The charging connectors installed on the EVSE may vary depending on the designated application.



Manufacturer Contact Info Sticker

