

DC Series

# DC 360kW Power Cabinet

User Manual & Installation Instructions

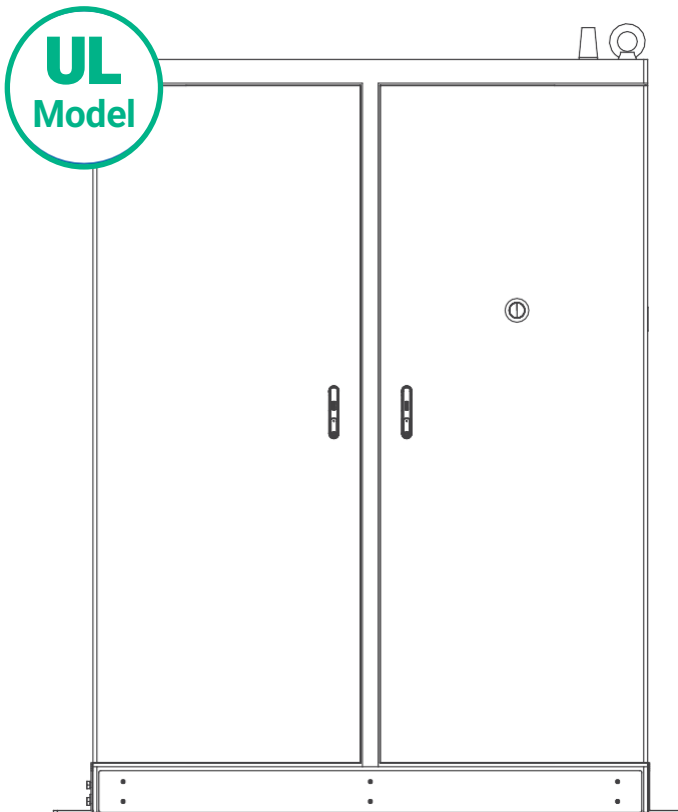

# CONTENT

<b>Introduction .....</b>	<b>1</b>
<b>Features .....</b>	<b>1</b>
<b>Applications.....</b>	<b>1</b>
<b>1. Basic User Interface .....</b>	<b>2</b>
<b>2. Specification .....</b>	<b>3</b>
2.1 Product Specification.....	3
2.2 Dynamic Power Sharing info.....	5
2.3 Cable Connection (TN system).....	7
2.4 Dimensions .....	8
2.5 Direction of Cooling Airflow .....	8
<b>3. Installation Instruction.....</b>	<b>10</b>
3.1 Before Installation .....	10
3.2 Grounding and Safety Requirements.....	16
3.3 Install Sensor Board for Safely Shutting Down (Optional).....	17
3.4 Unpack the Charger .....	21
3.5 Recommended Tools for Installation and Inspection .....	24
3.6 Installation Procedure.....	27
3.7 Installation Inspection & Commissioning.....	44
<b>4. Charger and Network Setting .....</b>	<b>48</b>
4.1 Wi-Fi Network Setting .....	48
4.2 3G/4G Setting.....	50
4.3 Time setting.....	52
<b>5. Maintenance .....</b>	<b>54</b>
5.1 Status Codes .....	54
5.2 Before Maintenance .....	54
5.3 General Maintenance .....	54
5.4 Replacement Kits and Accessories .....	56
<b>6. Limited Product Warranty.....</b>	<b>57</b>
<b>Appendix 1 - Package List.....</b>	<b>59</b>
<b>Appendix 2 - Maintenance Period.....</b>	<b>60</b>
<b>Appendix 3 - Wire and MCCB Recommendation .....</b>	<b>61</b>
<b>Appendix 4 - Standard Design Power Cabinet .....</b>	<b>63</b>





## Introduction

The DC Power Cabinet Fast Charger is the top choice to power battery electric vehicle (BEV). It is designed for quick charging in both public and private locations, such as retail and commercial parking spaces, fleet charging station, highway service area, workplace, etc.

The DC Power Cabinet Fast Charger has the advantage of easy installation. The pluggable power modules realize flexible and cost-effective installation for different types of locations. The DC Power Cabinet charger also has network communication capability. It is able to connect with remote network systems and provide drivers of electric cars real-time information, such as the location of charging stations, charging progress and billing information. The DC Output Power Cabinet Fast Charger has a clear user interface with function buttons, safety certifications and an excellent waterproof and dust proof design to provide the best choice for outdoor environments.

## Features

- Pluggable power modules make installation easy and flexible.
- Offers customers the convenience of start/stop charging control from an authorized RFID smart card or mobile APP.
- Built according the latest industry standards.
- Carries an outdoor rating capable of withstanding solid and liquid intrusions in outdoor settings making the unit more stable and highly reliable.
- Provides a high-contrast, screen interface with multi-function buttons.
- Upgradeable to simultaneously 4 DC charging, up to 360KW per output with liquid-cooled connector up to 500A.

## Applications

- Public and Private Parking Area
- Community Parking Area
- Parking Area of Hotel, Supermarkets and Shopping Malls
- Workplace Parking Area
- Charging Station
- Highway Rest Area



# 1. Basic User Interface

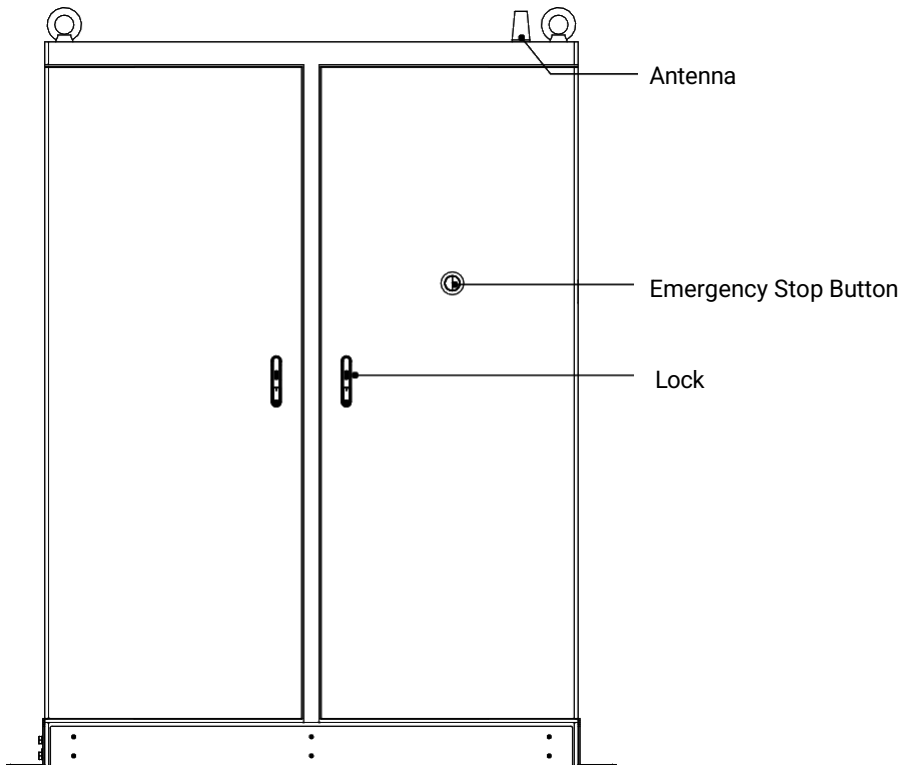



## 2. Specification

### 2.1 Product Specification

Model Name		DOWx362 Series
AC INPUT	Input Voltage	480 VAC, 3 Phase (+10%, -15%)
	Input Current Rating	466A@277Vac 549A@235Vac
	Electrical Distribution	3P+ N+ PE (Wye Connection )
	Power Grid System	TN/TT
	Frequency	50/60Hz
	Max. Input Power	391 kVA
	Power factor	> 0.99
	Efficiency	94%, at optimize V/I point
	SCCR	25kA/65kA (optional)
DC OUTPUT	Maximum Output Voltage	950Vdc
	Simultaneously output mode	0%, 25%, 50%, 75%, 100% of 360kW
	Voltage Accuracy	±2%
	Current Accuracy	±2%
Electrical Isolation	Isolation between input and output	
Standby Power	< 100W	
Communication	External	Ethernet, Wi-Fi and 3G/4G
	Internal	CAN / RS485
Input Protection	OVP, OCP, OPP, UVP, SPD	
Output Protection	SCP, OCP, OVP, LVP, OTP	
Internal Protection	OTP, AC contactor detection, DC contactor detection, Fuse detection	



*AC breaker capacity selection	Current rating of MCCB be over than or equal to 600Amp (360kW)	
User Interface & Control	Display	None
	User Authentication	None
	Backend support	OCPP 1.6 JSON
Environmental Conditions	Operation Temperature	-30°C to 50°C (-22°F to 122°F), will derating from 50°C (122°F) and above
	Storage Temperature	-40°C to 70°C (-40°F to 158°F)
	Relative Humidity	5%~95% RH, non-condensing
	Altitude	≤ 2000m (6561ft)
Regulations	Safety	UL2202, UL2231
	EMI/EMC	FCC CFR Title 47 Part 15 Subpart B: 2020 ANSI C63.4: 2014 ICES-003:2020 Issue 7
Mechanical Specifications	Dimensions (WxDxH)	1400x800x1900 mm (55.12"x31.50"x74.80")
	Weight (typ.)	< 1200 kg (2645.55 lb)
	DC outputs interface	Terminals x 4 sets
	Cooling	Forced Air
	Ingression Protection	NEMA3R
	Anti-vandalism	IK10



## 2.2 Dynamic Power Sharing info

Dynamic Power Sharing (Four-Connector Model Only). According to the standard 360kW power cabinet DC output, the power dispenser connectors maximum output as below list:

1. The connectors will get full 360 kW when only one connector is plugged in or the rest three connectors finish the charging session.
2. Each connector will get 180kW (50%) or 90kW (25%) and 270kW (75%) output power when Two connectors are plugged in simultaneously or the rest two connectors finish the charging session, depends on the electronic vehicles' charging power request.
3. The connectors will get 90kW (25%), 90kW (25%) and 180kW (50%) output power when Three connectors are plugged in simultaneously or the fourth connector finishes the charging session, depends on the electronic vehicles' charging power request.
4. The connectors will get equal sharing (90kW each) output power when Four connectors are plugged in simultaneously. If any particular specification, please contact the manufacturer for more information.

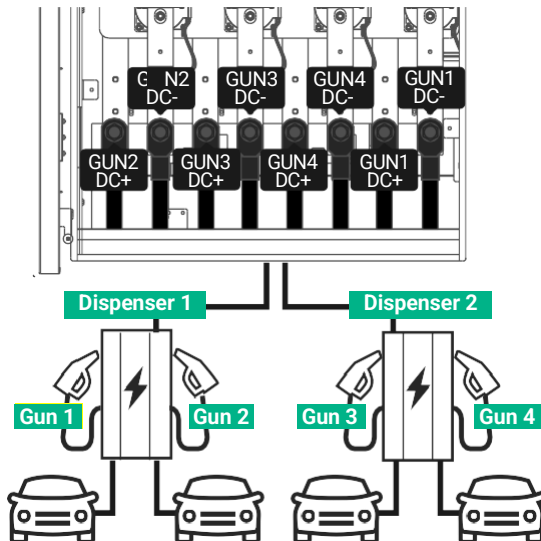





	Gun 1	Gun 2	Gun 3	Gun 4
One Car	360kW	X	X	X
Two Cars	180kW	180kW	X	X
Two Cars	180kW	X	180kW	X
Two Cars	90kW	X	X	270kW
Two Cars	X	90kW	270kW	X
Three Cars	180kW	90kW	90kW	X
Three Cars	90kW	180kW	X	90kW
Three Cars	90kW	90kW	180kW	X
Three Cars	X	90kW	90kW	180kW
Three Cars	90kW	90kW	X	180kW
Three Cars	90kW	X	180kW	90kW
Four Cars	90kW	90kW	90kW	90kW



## 2.3 Cable Connection (TN system)

\*Adapted for two cabinets version

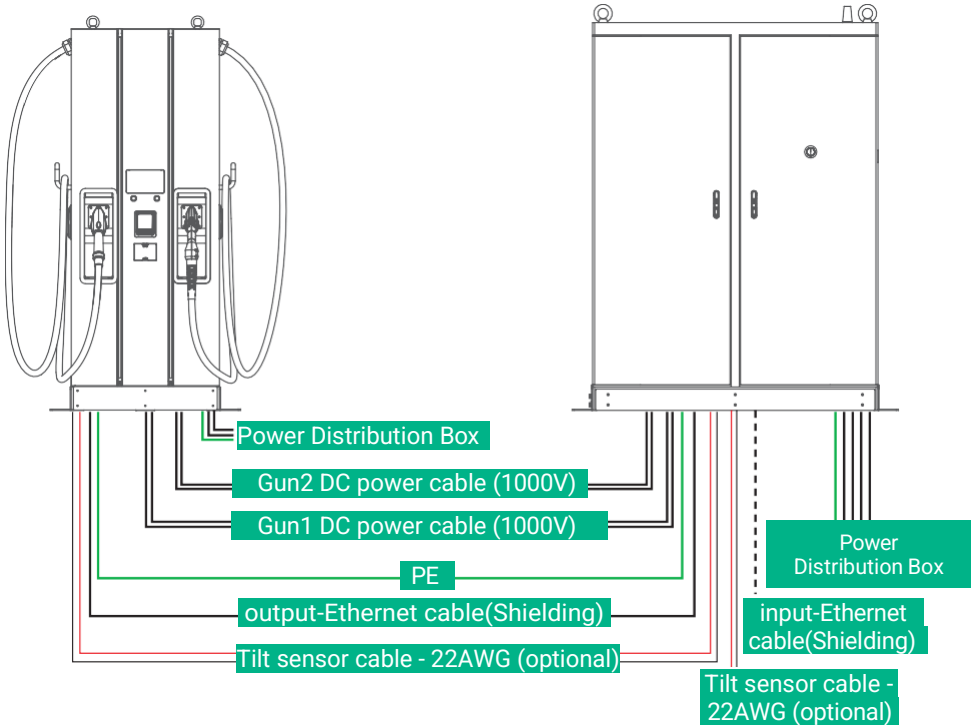

### NOTE:

- The maximum DC voltage would be 950Vdc, the DC power cable be used should be able to withstand at least 1000V and required safe ampere capacity.
- Please note and confirm that all installation assemblies must comply with national safety standard and codes.
- The max. allowable distance between the power cabinet and the dispenser is 30m.
- The power cabinet and the distribution box are recommended to keep distance from the end users to have better operation experience.
- The similar design concept in appearance is recommended to the power cabinet and the distribution box.
- Must use the CAT6 SFTP cable 24AWG or 26AWG with CAT6A FTP RJ45 Plug or higher level cable/PLUG increased shielding for ethernet contact.



## 2.4 Dimensions

Unit:mm(inch)

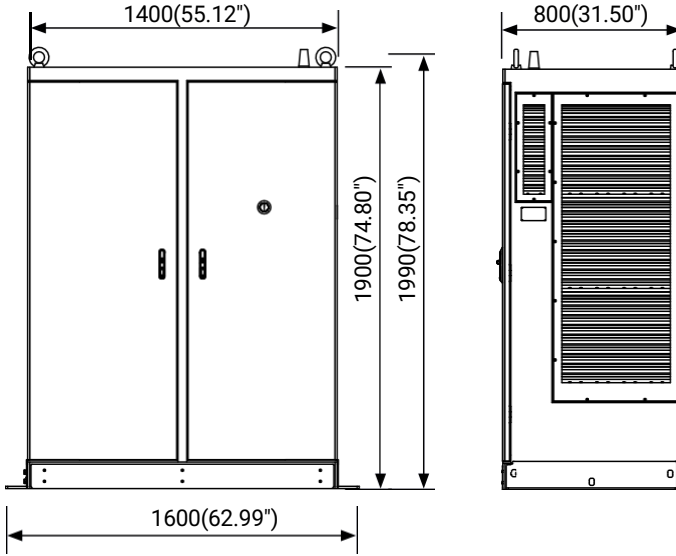

## 2.5 Direction of Cooling Airflow

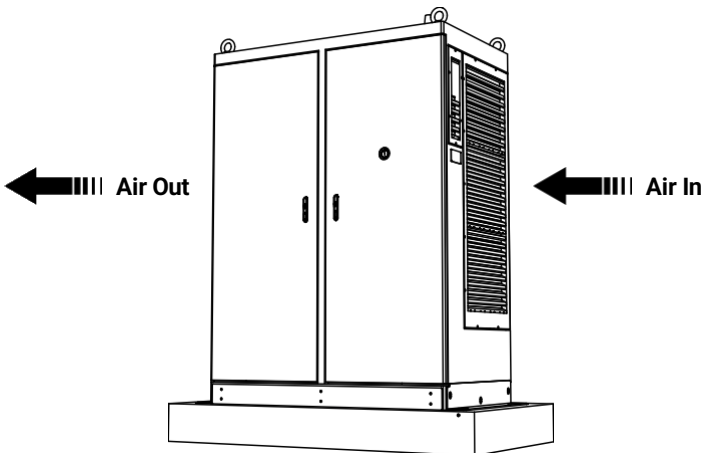



The following signs are used on the equipment and in this manual:



**DANGER**  
**Hazardous voltage**

Identifies a hazard that could result in severe injury or death through electrocution.



**WARNING**  
**Various**

Identifies a hazard that could result in severe injury or death.



**WARNING**  
**Rotating parts**

Identifies a hazard that could result in injury due to the presence of rotating or moving parts.



**WARNING**  
**Pinch Hazard**

Identifies a hazard that could result in injuries in which some body parts are pinched or crushed.



**CAUTION**  
**Various**

Identifies a hazard that could result in damage to the machine, other equipment, and/or environmental pollution.



**NOTICE**  
Contains remarks, suggestions or advice.



## 3. Installation Instruction

### 3.1 Before Installation

- Read all the instructions before using and installing this product.
- Do not use this product if power cable or charging cable have any damage.
- Do not use this product if the enclosure is broken, open or has other damage.
- Do not put tools, materials, fingers or other body parts into the charger or EV connector.
- The product should be installed only by a licensed contractor, and/or licensed technician in accordance with all building codes, electrical codes and safety standards.
- The product should be inspected by a qualified installer prior to initial use. Under no circumstances will compliance with the information in this manual relieve user of his /her responsibilities to comply with all applicable codes and safety standards.
- Power feed must be 3 Phase Wye Connection with one of TN/TT grounding systems.
- The capacity of power supply should be higher than 196kVA (180kW application) or 391kVA(360kW application) in order to have function correctly.
- The product should be installed in a free air area and need sufficient space for product installation and maintenance, keep at least 100cm(39.37") clearance distance to the product



## 3.1.1 Contractor Safety Guide

### Introduction

- A safe work environment for everyone - participants, installation and demolition crews, contractors and subcontractors.
- Ultimately, it is the responsibility of contractors to ensure the safety and safe work practices of their employees and subcontractors who may be working at the site on their behalf.
- This guide provides a simple reference guide with basic rules for implementation. This guide does not outline every single safety standard: it is designed to be a supplement to participants, contractors and subcontractors.
- Contractors, subcontractors and employees should cooperate with their employers and other persons in complying with safety regulations and instructions.

In particular, installation workers should:

1. Obtain the qualified authorization of the responsible unit in the construction area.
2. Work safely.
3. Not do anything to endanger themselves or other persons.
4. Use personal protective equipment as required and take reasonable care of it when it is not in use.
5. Report unsafe activities immediately to supervisors or the responsible person in control of the workplace.
6. Report all accidents and dangerous occurrences to the supervisor immediately after they happen.



## 1. Requirements for workplace conditions

- Set up suitable fencing to isolate the construction area from outside
- Close and secure all entrances when the site is unattended
- Hang warning notices nearby which show the following information: warning icon and phone number of person in charge
- Install sufficient lighting fixtures



- Keep work areas (including accessways) free from debris and obstructions
- Keep ground surfaces tidy and flat, to avoid people tripping or being hurt by tools or other objects
- Stack and store equipment and materials in a tidy and stable manner
- Regularly clean up and dispose of waste
- Remove all surplus materials and equipment after completion of work



- Beware of flammable materials and goods. Keep them away from work areas.





#### 4. Protection against high temperatures on the worksite

- Erect a sunshade or shed to shelter workers from the heat and sun
- Set up cooling equipment, such as exhaust fans
- Make water dispensers available
- Provide suitable protective clothing such as hat, sunglasses and long sleeves to protect workers from heat stroke and UV rays



#### 5. Inclement weather

- Secure all scaffoldings, temporary structures, equipment, and loose materials
- Check and implement SOP to ensure disconnection of gas supplies, electrical circuits and equipment
- Inspect worksites to ensure protection against ingress of water or dust
- Inspect the drainage system for blockages and remove if found
- Stop all outdoor works except for emergency works



#### 6. Ladders

- Only use ladders that meet local safety regulations
- Do not use wooden ladders
- When working at height, it is recommended to use platforms instead of ladders
- If using a platform is not practicable, a supervisor should assess the potential risk and provide safety



- protection equipment for workers
- Use non-conductive ladders made of glass-fiber or reinforced plastic when carrying out electrical work
- Assign assistants to provide support when working on ladders
- Check all ladders for broken rungs or other defects before use and periodically
- Fully open stepladders when in use
- Do not stand on the top two rungs of a ladder
- Do not overreach when working on a ladder
- Beware of overload restrictions



Country	Standards
British	BS1129,BS2037,EN131,EATS13/1
USA	ANSI A 14.1,ANSI A 14.2,ANSI A 14.5
Australia New Zealand	AS 1892.2-1922,AS/NZS1892.1,AS/NZS 1892.3
Canada	CSA Z11 M81

**Common Standards for Ladders**

## 7. Working at height

- Avoid working at height by using alternative tools and methods as far as practicable
- It is strongly recommended to build suitable scaffolding or work platforms
- Provide fall arrest systems for workers if it is impracticable to use working platforms
- Secure all materials and tools to prevent them falling from height





## 8. Lifting operations

- Have lifting gear and apparatus regularly inspected and tested by qualified persons
- Isolate and cordon off lifting areas to keep out non-construction personnel
- Ensure that lifting routes do not cross buildings or people, and avoid collision with objects
- Do not exceed safe working load limits



## 9. For on-site workers

- Plan all work
- Turn off power (work with live parts de-energized whenever possible)
- LOTO (Lock Out, Tag Out)
- Live electrical work permit (input terminals with HV after door open)
- Use personal protective equipment (PPE)
- Safe workplace conditions and space
- Adhere to other occupational health, safety and security codes, such as those published by OSHA



## 10. Reference standards

Adhere to the following codes:

- NFPA-70E -2021 Sec 110.3 (Electrical Safety in the Workplace)
- NFPA-70E -2021 Sec 130.4 (Shock Risk Assessment)
- NFPA-70E -2021 Sec 130.5 (Arc Flash Risk Assessment)





## 3.2 Grounding and Safety Requirements

- The product must be connected to a grounded, metal, permanent wiring system. Connections shall comply with all applicable electrical codes. Recommend ground resistance is less than  $10\Omega$ .
- Ensure no power is connected at all time when installing and maintaining.
- Use appropriate protection when connecting to main power distribution network.
- Use appropriate tools for each task.

### 3.2.1 Service Wiring

#### • Ground Connection (TN System)

Always connect the Neutral at the service to Earth Ground. If ground is not provided by the electrical service then a grounding stake must be installed nearby. The grounding stake must be connected to the ground bar in the main breaker panel and Neutral connected to Ground at that point.

#### • 480Vac Three-Phase(Line to Line)

#### CAUTION!



This is feed from 3 Phase / Wye Connection power grid, the DC Cabinet Fast Charger should connect to L1, L2 or L3, and Neutral. Earth ground must be connected to neutral at only one point, usually at the breaker panel.

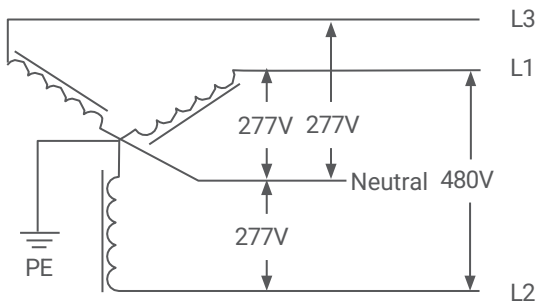

480V Three-Phase Wiring Connection



### 3.3 Install Sensor Board for Safely Shutting Down (Optional)

- 1. Introduction:** To prepare a control board which includes door sensor sensing function and tilt sensor, also dry contact points for extending wiring to upstream circuit breaker in order to cut off power immediately when sensors triggered. This board also has self-test button which uses to verify if it functions properly no matter in production line or in installation site or during regular maintenance service.

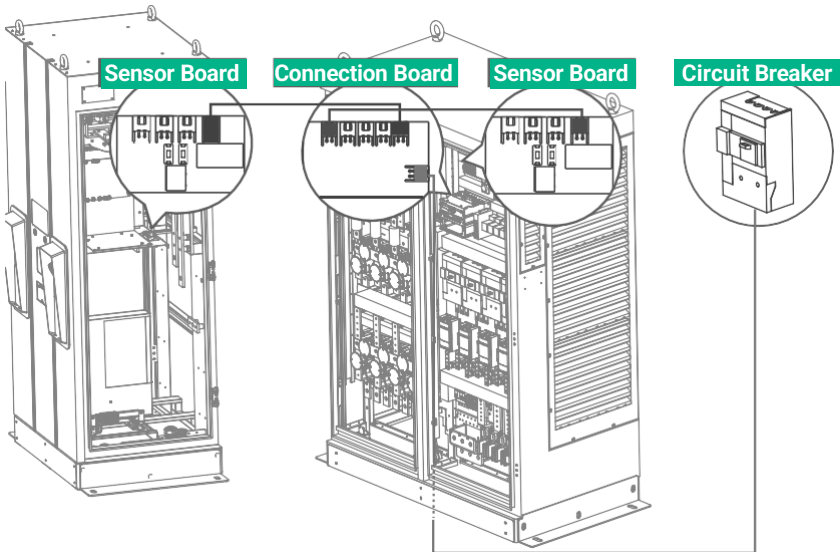

#### 2. Function Block Diagram:

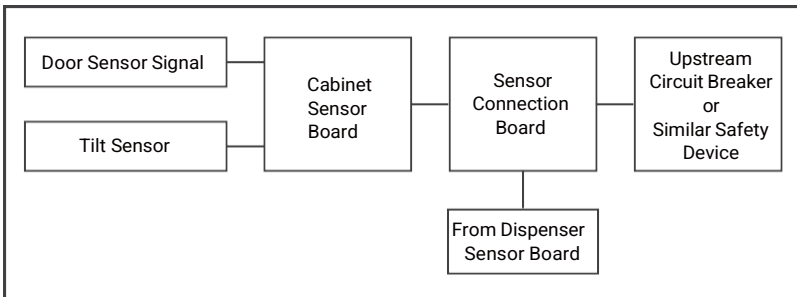



### 3. Connecting Board:

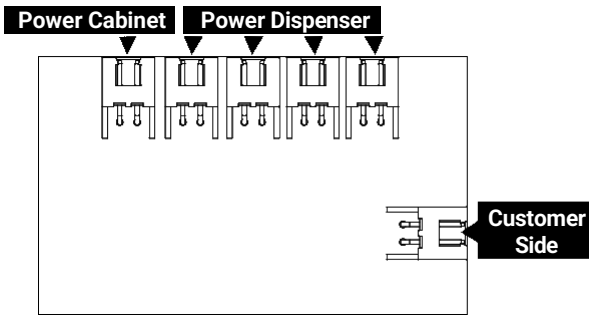

### 4. Sensor Board:

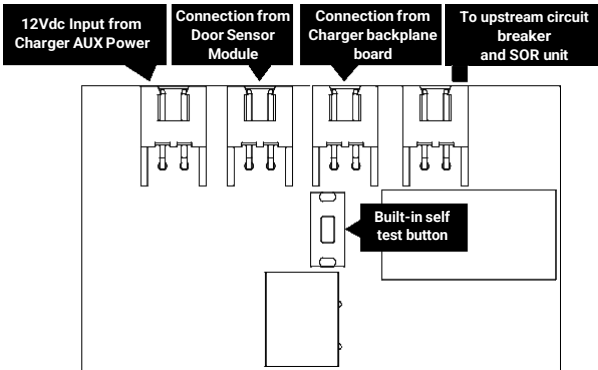

### 5. Sensor Board functions:

- a) When either door sensor or tilt sensor been trigger, it will send a voltage to trip off or open or cut off power of upstream circuit breaker or safety device.

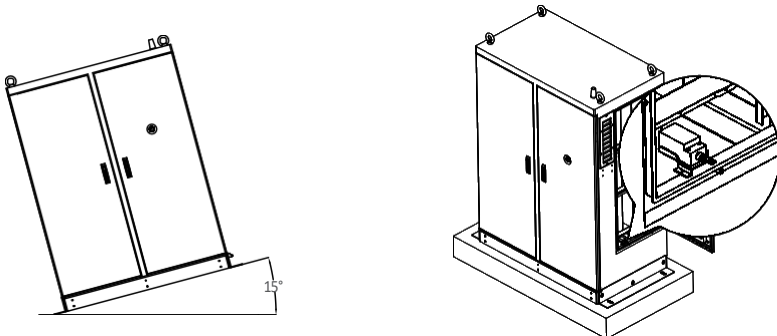



- b) When upstream circuit breaker been cut off, the charger will be totally shut down then goes into “off line” status immediately, it won't be recover remotely, only relies on service people to be presented on site.
- c) This board has self-test button to test if it stays function properly during installation or regular maintenance service.

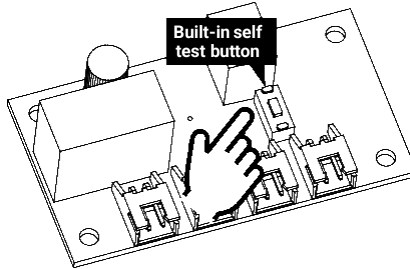

#### **6. Sensor Board Connection Functions:**

- a) Power Cabinet and Dispenser tilt sensor signal combination.
- b) When the separate cabinet triggers a signal, notify the client to Link Breaker.

#### **7. Upstream circuit breaker selection and aux power preparation:**

Constructor or CPO is mandatory to select a circuit breaker which with “shunt release accessory” or relevant devices so that the safety function can be activated. If you need any recommendation models of shunt release, please contact your local agent. Below are reference SOR reference models from ABB:

12V : SOR-C 12V DC (1SDA066321R1)

24V : SOR-C 24-30V AC/DC (1SDA066322R1)

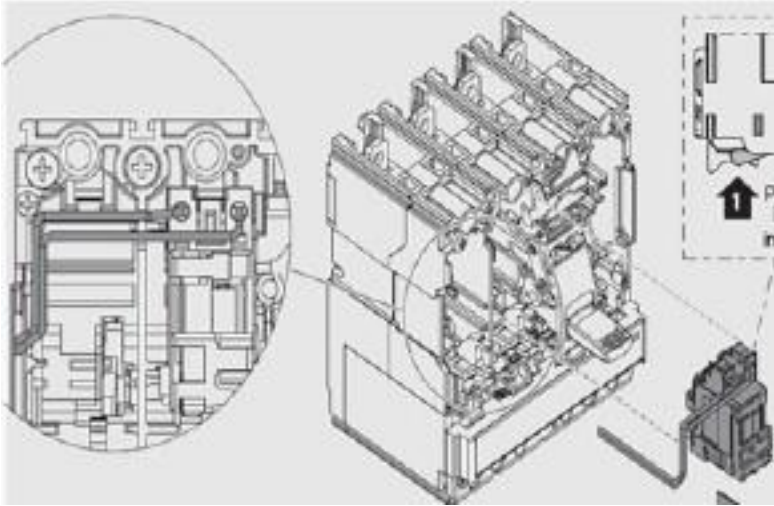

### NOTICE

For the parts of SOR, maximum 277Vac withstand voltage is required.

## 8. Wires Spec Selection:

The wires from sensor board to upstream circuit breaker is recommended UL1015 22AWG 105°C 600V or relevant.

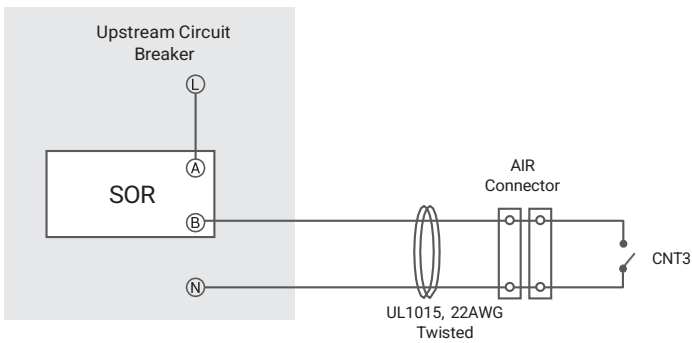

### Control Circuit



## 3.4 Unpack the Charger

- The product is Direct current (DC) charger, the packing design passed the packaging simulation test, if the packaging is damaged cause by overturning, falling or external impact during transportation, it may cause the product damage or defects. if there is any serious damage to the packaging when receiving the goods, please notify manufacturer about your findings.
- Receiving the DC 360kW Power cabinet. The product is delivered by a transport company to a warehouse or specified location where it will be handed over. Transporting the DC 360kW Power cabinet to its final location (last mile service) is not standard included in the order.

**NOTICE:** The delivery truck unloads the pallet carrying the DC 360KW Power Cabinet. The movement of the DC 360kW Power cabinet to its final location is the responsibility of the customer / contractor.



- Checking the TiltWatch PLUS sensors: If the TiltWatch PLUS indicator is tilted over 30°
  1. Do not refuse the delivery / receipt.
  2. Make a notation on the delivery receipt and inspect cabinet for damage.
  3. If damage is discovered, leave cabinet in original package and request immediate inspection from carrier within 3 days of delivery.
  4. Contact manufacturer by mail or phone to notify us about your findings



### **WARNING!**

Charger weight with packing may > 1200 Kg(2645.55 lb)!  
Be careful during unpack process.





## STEP 1.

Please disassemble the shipping crate as follows:

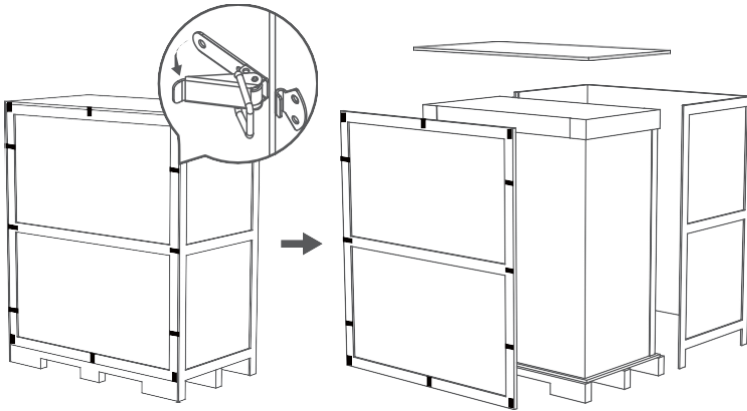

## STEP 2.

Please remove the cardboard box and the protective internal packaging as follows:

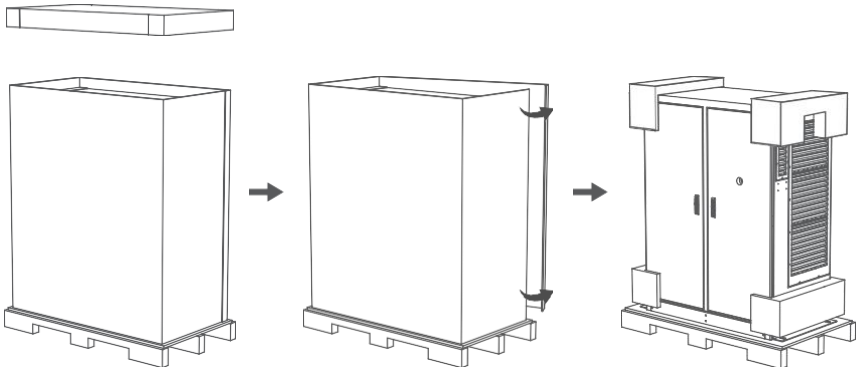



### STEP 3.

Remove the 4 fixing screws.

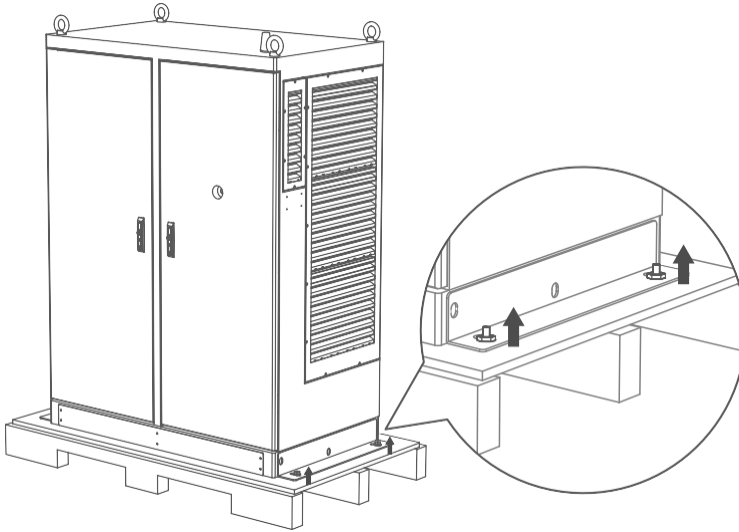

### Note

To use lifting eye bolts to move the EVSE, please apply 6mm (1/4 inches) diameter steel wire rope to the four eye bolts as following picture. (Make sure to tighten the eye bolts before lifting.)

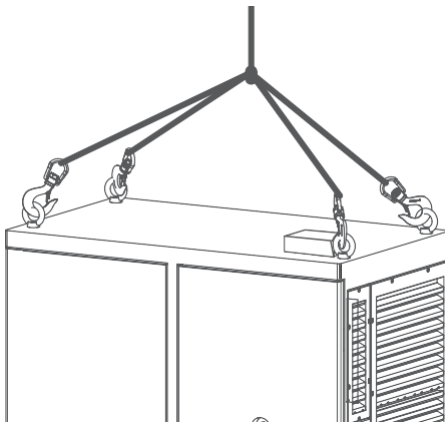





## 3.5 Recommended Tools for Installation and Inspection

### 3.5.1 Recommended Tools and Assemblies for Installation

Type	Description
Philips Screwdriver	No.1, No.2
Hexagon Screwdriver	5.5mm, 7mm, 8mm, 10mm,13mm, 17mm, 19mm, 24mm, 30mm *See the table of metric conversion
Shifting Wrench	12" (34mm)
Electrical tape	Black/15mm (0.6") Width
Combination wrench (for DC /PE CABLE)	FNW-19, FNW-24
AC Input Cable	<p><b>Power Line:</b>            Conductor cross section: 350kcmil(177mm<sup>2</sup>) at least, Cable x 8; L1x2, L2 x2, L3x2, Nx2. (360kW) MAX            With Ring terminal for M16 screw (Inner diameter &gt; 16mm (0.63"), Outer diameter &lt; 51mm (2"); thick type).            Recommend to use 600V, 75° C (167°F), XLPE/XHHW-2/ Hypalon/Photo-Voltaic power cable.</p> <p><b>Protective Earth conductor :</b>            Conductor cross section: 1AWG (42.4mm<sup>2</sup>), cabledx1 for TN system with ring terminal for M16 screw (Inner diameter &gt; 16mm (0.63"), Outer diameter &lt; 35mm (1.37") ; Thick type)            (Conductor cross section: 1AWG (42.4mm<sup>2</sup>) ground rod for TT system )</p>
DC Output Power Cable & PE	<p>DC Output x2 (Gun1, Liquid cooling; Gun2, Natural cooling)            (The charging connectors installed on the EVSE may vary depending on the designated application.)</p> <p><b>Each connector is recommended to use below cable:</b>            Liquid Cooling 500A CCS1/CCS2-Conductor cross section:            Conductor cross section: 250kcmil (127mm<sup>2</sup>) at least, Cable x 4 (DC+ x2, DC- x2 )            Natural Cooling 300A CCS1/CCS2- Conductor cross section:            350kcmil (177mm<sup>2</sup>) at least, Cable x 2 (DC+ x1, DC- x1 )            Natural Cooling 200A CCS1/CCS2, CHAdeMO 200A            Conductor cross section: 3/0 AWG (85.01mm<sup>2</sup>) at least, Cable x 2 (DC+x1, DC- x1)            With ring terminal for M16 screw (Inner diameter &gt; 16mm (0.63" ), Outer diameter &lt; 40mm (1.57")); Thick type)</p>



	 <p>Recommend to use 1000V, 75°C (167°F), XLPE/ XHHW-2/Hypalon/Photo-Voltaic power cable.</p>  <p>Protective Earth conductor: Conductor cross section: 2AWG (33.62mm<sup>2</sup>) cable for TN system With ring terminal for M16 screw (Inner diameter &gt; 16mm (0.63”), Outer diameter &lt; 35mm (1.37”); Thick type) (Conductor cross section: 2AWG (33.62mm<sup>2</sup>) ground rod for TT system )</p>
Ethernet cable	CAT6 SFTP cable 24 AWG or 26 AWG x 2 for dispenser cabinet
Slotted Screwdriver	
Socket driver	
Forklift	
Wire Stripper	
Wire cutters	
Residual Current Device	30mA type A , 4 pole
MCCB(Moulded Case Circuit Breaker)	over than or equal to 600A 4 pole; B curve



Please consult your local electrical technicians for proper installation instructions as installation requirements or conditions may vary on-site.

SCREW SIZE		RECOMMENDED TORQUE			
METRIC (MM)	ENGLISH (inches)	DIN(Nm)		ASTM (ft'lb)	
		6,9 QUALITY	8,8QUALITY	A449 TYPE	A325TYPE
M3	1/8	1	1,3	-	
M4	5/32	2,5	3		
M5	3/16	4	6		
M6	1/4	5	10	4	
M8	5/16	20	23	9	
M10	7/16	40	50	25	
M12	1/2	60	70	38	50-58
M14	9/16	100	120	54	-
M16	5/8	150	210	75	99-120



### 3.5.2 Recommended Tools for Inspection & Commissioning

Type	Description
EV or EV Simulator	Meet CHAdeMO/CCS Standard
Multi-meter	1000V
Current Probe	600Amp
RFID Authorized Card	
RFID No Valid Card	
Door Key	
Needle-Nose	
Laptop & CAT6 Cable	
Wi-Fi, 3G/4G signal quality checker	If wireless router is used, please do not leave the router in metal box for better signal strength.



## 3.6 Installation Procedure

### 3.6.1 Required Space for Placing and Maintaining

required a space of 2600 x 1600 mm. This space is calculated as follows:

- Size Charge W x D x H: 1400 x 800 x 1900 mm.
- Front side 850 mm, in order to open the front door.
- Left and right side 600 mm, in order to open left and right door.
- Backside 100 mm, in order to guarantee an unimpeded airflow.
- The distance from ground screws to the RC concrete edges should be at least 100mm.

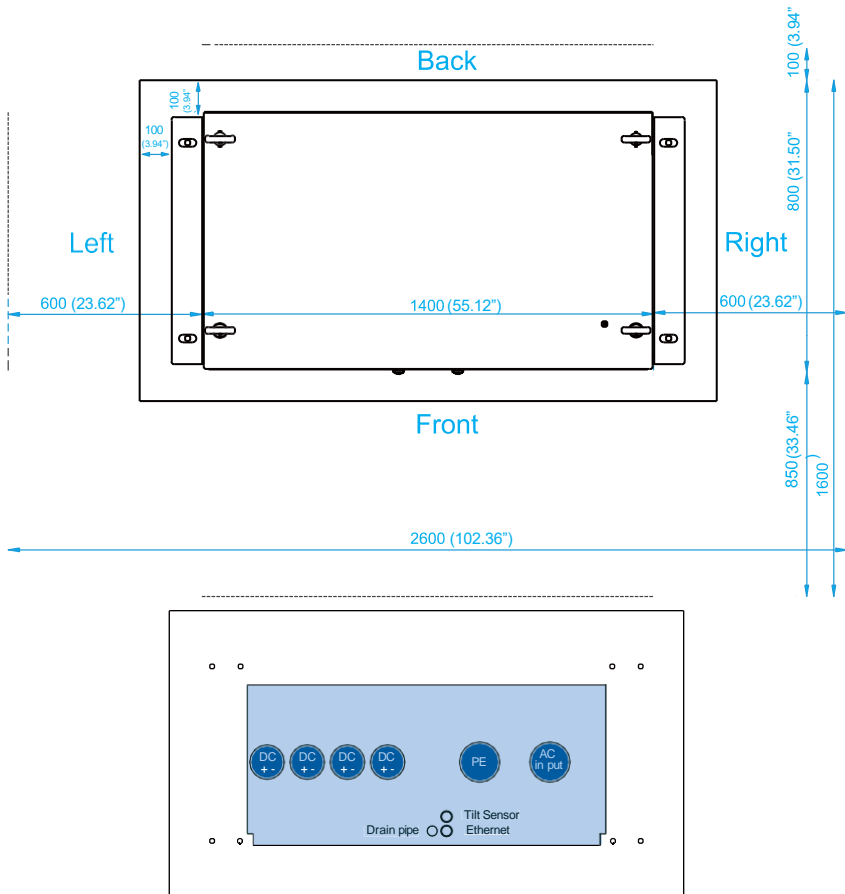



## 3.6.2 Build Concrete Base

### STEP 1.

- 1- Build 1800mm(72") x 1000mm(40") x 200mm(8") RC concrete base on the level to stand charger in advance.
  - 2- Implant 5" conduit for AC input cable, 5" conduit for PE cable, 4" conduit for DC output cable, 1" conduit for tilt sensor cable, 1" conduit for Ethernet, 1" drain pipe.
  - 3- And install the 4 pcs of M16 mounting anchor bolts and leave at least 50mm(2") thread length enough for 2 pcs of M16 nuts to be fasten on each after the unit has been fitted onto the base. The positioning of these 4 pcs of M16 screws should be within  $\pm 2$ mm in short axis,  $\pm 2$ mm in long axis according to screw holes of charger.
  - 4- Add drain pipe at opening of concrete base to prevent water/moisture accumulation.
- \* Recommend to use a prefabricated steel mold for constructing the cement concrete base per dimensions provided below.

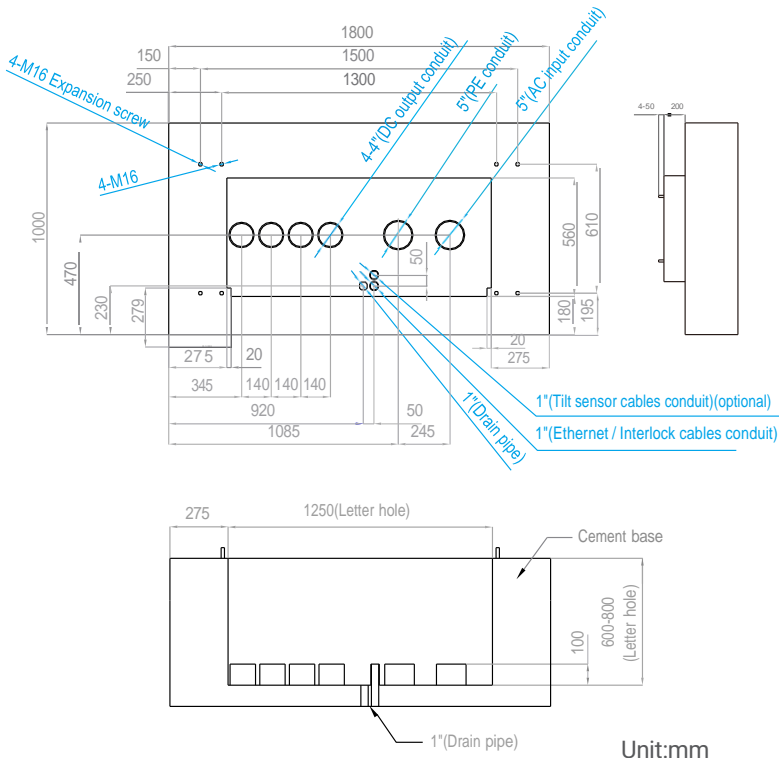

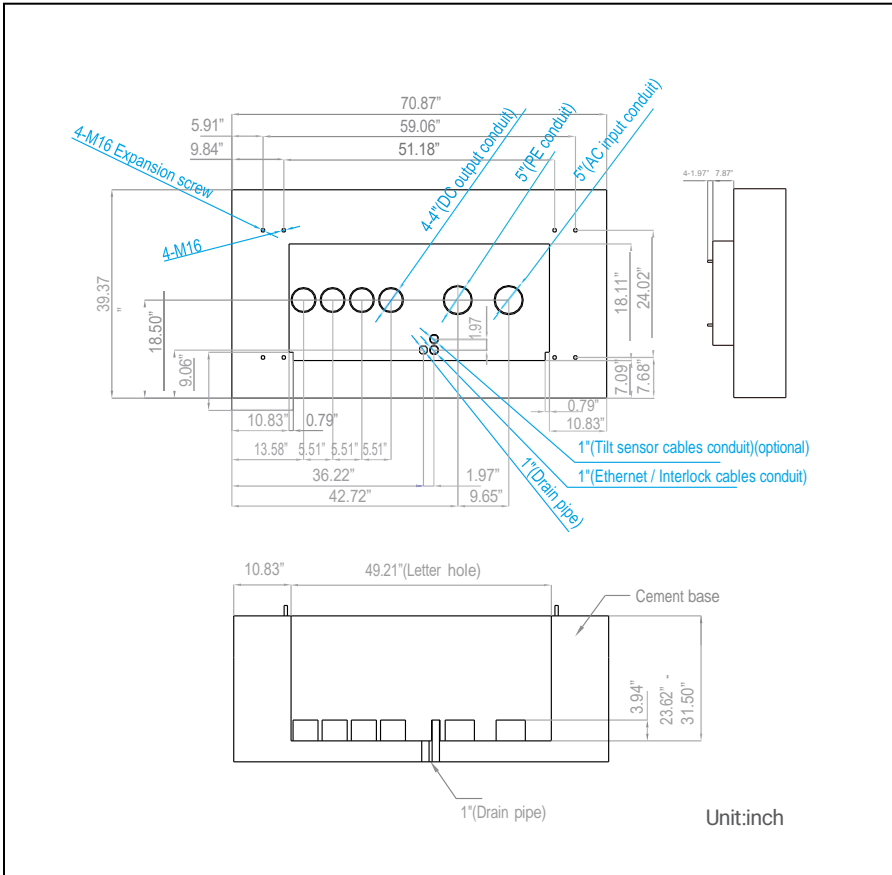

## STEP 2.

- Extend 3 phase 5 wires AC input cable from conduit of concrete base, AC cable expose at least 520mm(20.47") PE cable expose at least 380mm (14.96") and these wires should be with ring terminals.
- The conductor cross sectional area of input power wires should be not less than 350kcmil\*2. Extend 8 wires DC output cable from conduit of concrete base, DC cable expose at least 320mm(13") and these 8 wires should be with ring terminals. The conductor cross sectional area of output power wires be recommended at section 3.4.1.
- Extend communication wire from conduit of cement base, expose at least 280mm(12").



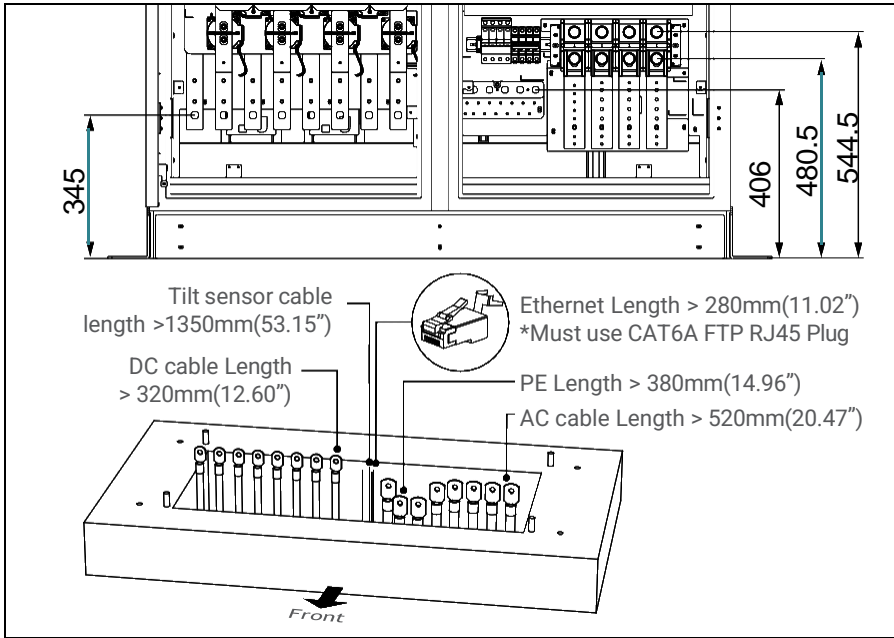



### 3.6.3 Two Methods of Fixing the Charger Method 1

#### Method 1.

Lift the charger onto the concrete base, feed all the cables through the entry hole located at the bottom of the unit; fasten the 4 pcs of M16 screw nuts on the 4 pcs of M16 mounting anchor bolt from the cement base (2 nuts for each bolt) to secure the chargers.

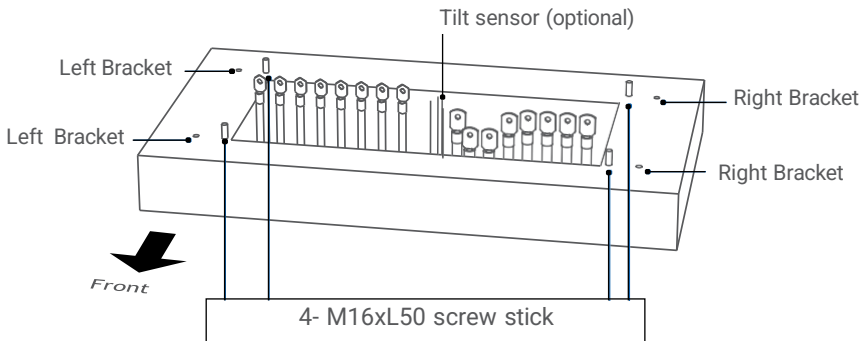



## Method 2.

Fix the cabinet with external brackets and expansion bolts.

Lift the cabinet onto the concrete base, remove the cover metal sheet of the cabinet base, fix the L-shaped brackets on the cabinet base with the M16xL120 expansion screws (Material: Stainless steel), drill 4x  $\Phi 20$  mm screw holes on the concrete base, secure L- shaped brackets on the concrete base by 4 pcs M16 expansion bolts (Material: Stainless steel).

Installation Precautions: During install the charging or stand, must ensure the equipment levelness to avoid the tilting of charging equipment affect the accuracy of tilt sensor operation.

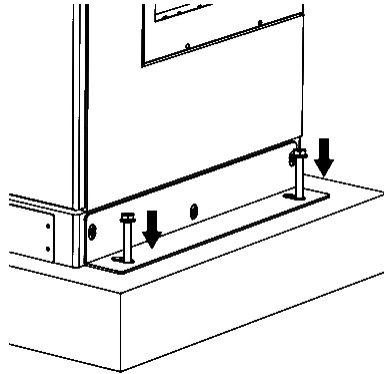

## Note

Remove the protective antenna EPE.

If remove the eye bolts on the top of the cabinet, must assemble the water-proof plastic bolts (in the accessory pack).

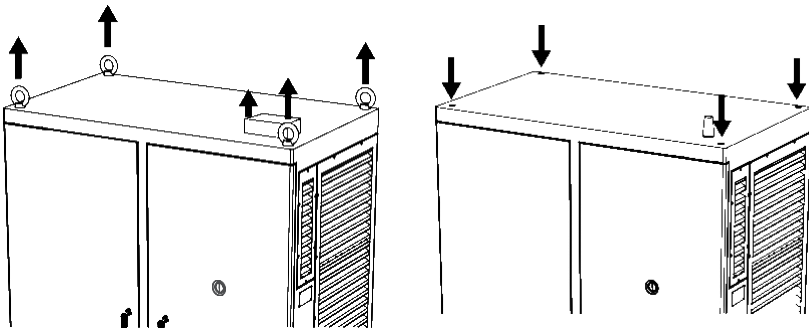



### 3.6.4 Pre-work for Lifting

#### STEP 1.

Open front door for wiring, loosen 6 pcs of screws to remove 2 set of cover plate .

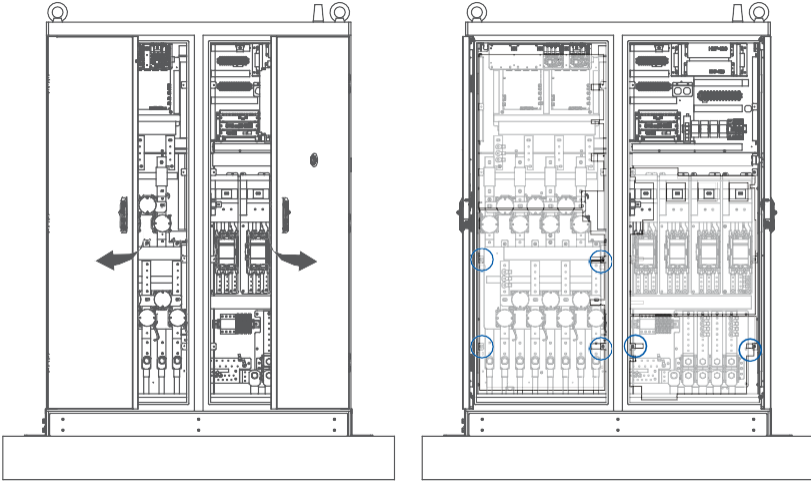



## STEP 2.

Unscrew 4 pieces of M5 screws of the 2 back covers, and 2 pieces of M5 nuts. Originally, the middle nuts of back cover is half loose and so can take the 2 back covers after unscrew the screws and nuts.

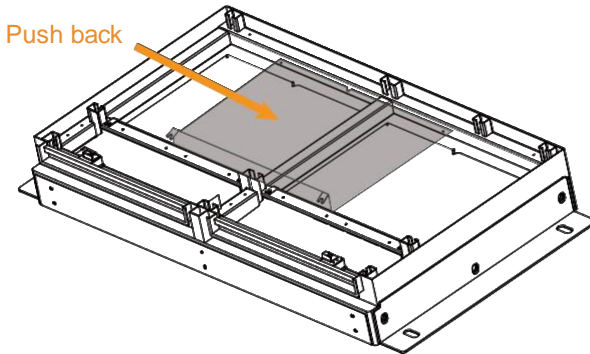
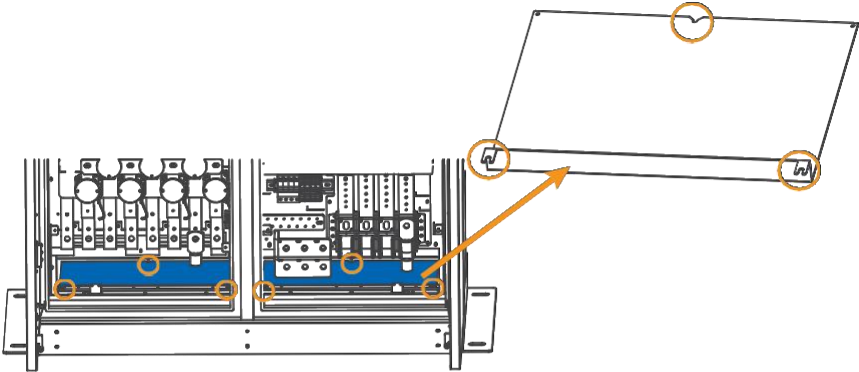

\*The purpose for the cover is prevent from invasion of insect or small animals  
It can be removed while installing if needed, just loosen screws on the cover,  
but remember to make cover fixed as original after installation



### STEP 3.

Unscrew the 1 piece of M5 screw of the two front covers and 8 pieces of M5 nuts, after that to take out the front cover.

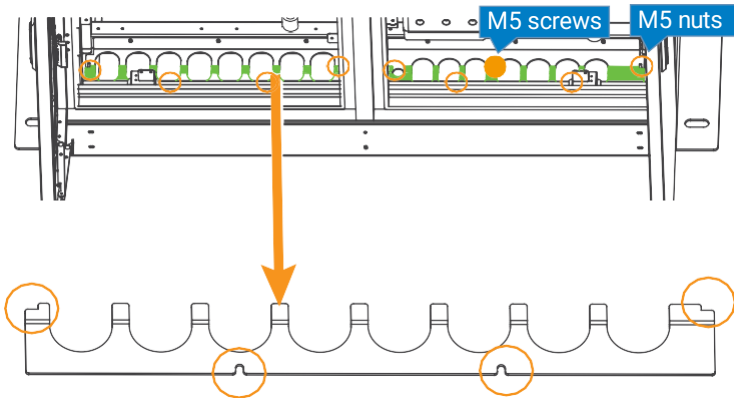

### STEP 4.

To use lifting eye bolts to move the EVSE, please apply 6mm (1/4 inches) diameter steel wire rope to the four eye bolts as following picture. (Make sure to tighten the eye bolts before lifting.)

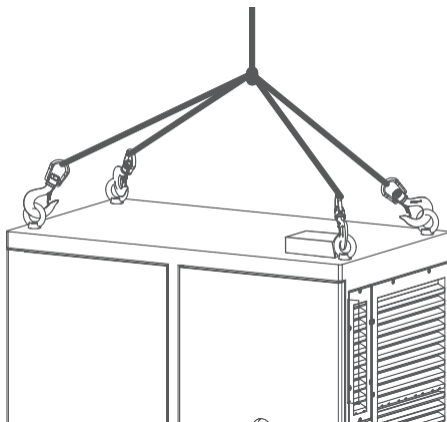



Or use a forklift to move the EVSE.

Step 1. Please remove the front and rear bottom trim panels first.

Step 2. Use a forklift to raise the EVSE.

(the fork must be opened to the maximum state)

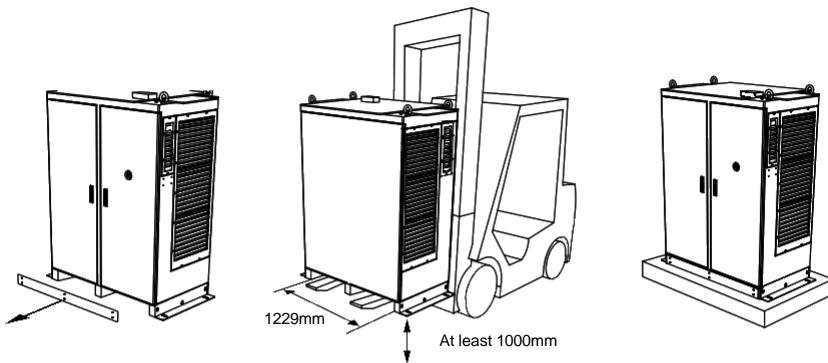



## STEP 5.

Arrange the wires to be pre-bended , and lift the EVSE.

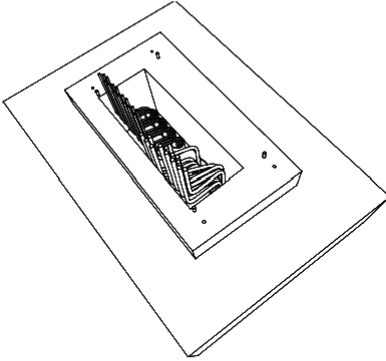

The situation of pre-bending wires in RC concrete base .

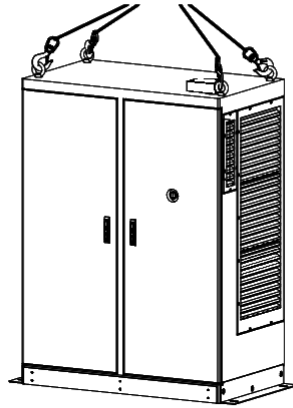

tilt sensor (optional)

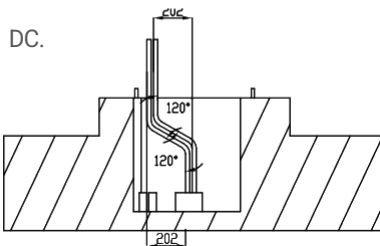
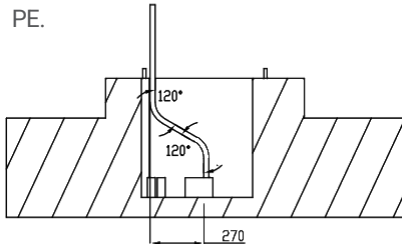
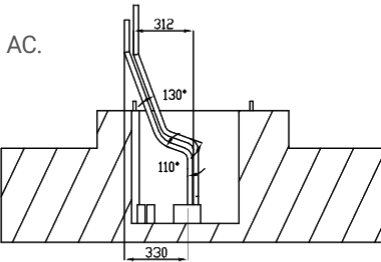
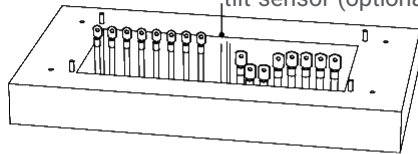





## STEP 6.

Fix the cabinet with external brackets and expansion bolts.

Lift the cabinet onto the RC concrete base, remove the cover metal sheet of the cabinet base, fix the L-shaped brackets on the cabinet base with the M16xL120 expansion screws (Material: Stainless steel), drill 4x  $\Phi 20$  mm screw holes on the RC concrete base, secure L-shaped brackets on the RC concrete base by 4 pcs M16 expansion bolts (Material: Stainless steel).

Installation Precautions: During install the charging or stand, must ensure the equipment levelness to avoid the tilting of charging equipment affect the accuracy of tilt sensor operation.

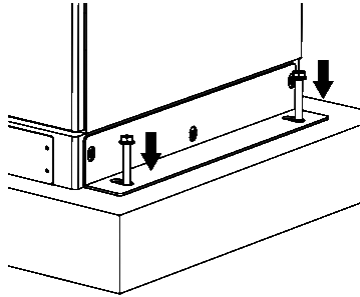



### 3.6.5 Installing Cable

#### STEP 1.

Put the pre-bending wires to to the front cover, and then put the back cover back. After put back, screw 1 pieces of M5 screws of the two front covers and 8 pieces of M5 nuts.(The structure of Generation 2 & 3 is the same.)

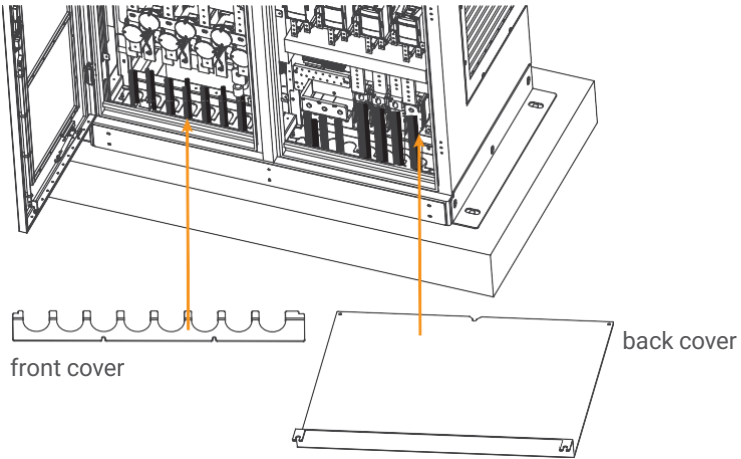



## STEP 2.

Connect the PE cable (green with yellow) to PE busbar plate; fasten input power cable L1 , L2 , L3 /Neutral on input terminal block accordingly. Connect DC+ and DC- power cable of GUN1、 GUN2、 GUN3 and GUN4 on relative position of busbar. Please fasten each wire with proper bolt and torque -350Kgf·cm/5-15 secs

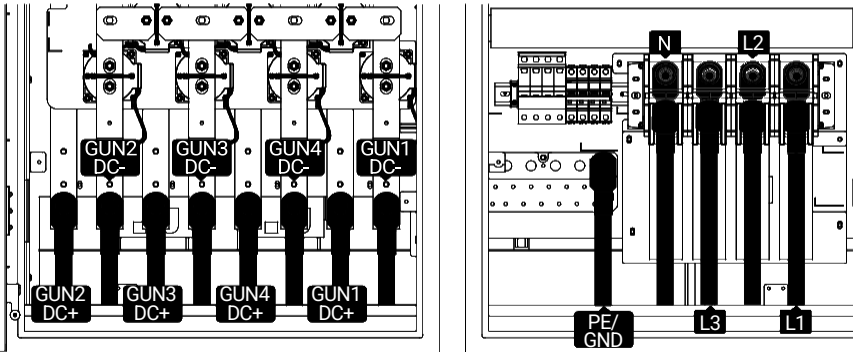

### Notes:

1. Precautions for the lock of the lower row of AC terminal blocks: first put the terminal -> copper row -> opening washer -> screw.
2. PE copper busbar: PE/GND is 03. Others are the PE points of the main cabinet and gun cabinet.



### STEP 3.

Connect Ethernet cable :

Insert input and output Ethernet cable into paired RJ45 connectors as pictures below. Tilt sensor cable into insulated butt splice connectors as pictures below (wire size: 22AWG).

1. For standard version

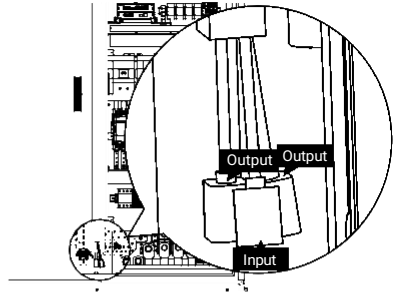

2. For tilt sensor version

Tilt sensor cable into insulated butt splice connectors as pictures below (wire size: 22AWG).

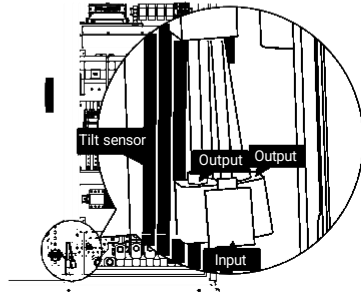



#### STEP 4.

Connect AC power cables to power distribution box, connect the Protective Earth wire (Green/Yellow) to ground point of power distribution box. Neutral should be shorted with PE to meet TN(-S) grounding system.

#### STEP 5.

To properly seal the cable entry after cables are installed, please fill and glue the cable entry with the sponge grommets provided in the accessory kit.

#### STEP 6.

Use adaptive flame retardants and electrical insulated foaming agent and far from conductive live part at least 12mm or other method to seal the cable entry hole to assure the NEMA3R grade of the cabinet, and prevent insects enter the cabinet.



600A MCCB B curve, with 30mA RCD type A and power meter are recommended to be used on power distribution box .

#### Note

Remove the protective antenna EPE.

If remove the eye bolts on the top of the cabinet, must assemble the water-proof plastic bolts (inside the accessory pack).

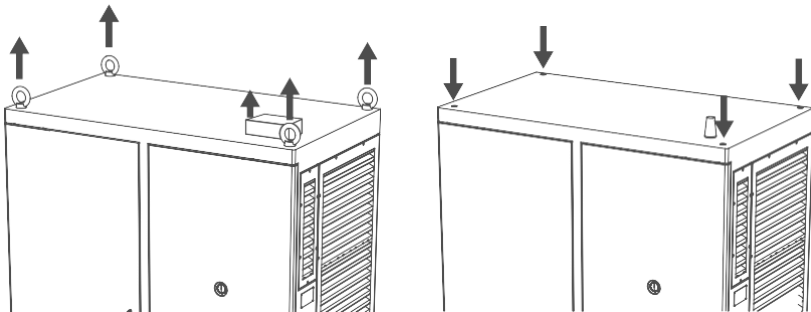



### 3.6.6 Screw Torque Requirement Table

Screw in Metric						
Screw size	Screw type	Steel Inch-Lbs	Steel kgf-cm	Steel N-m	Aluminum kgf-cm	Aluminum N-m
M2*0.4	Machine	3~4.77	3.5~5.5	0.34~0.54	3~4.5	0.34~0.44
M2.5*0.45	Machine	3~4.77	3.5~5.5	0.34~0.54	3~4.5	0.34~0.44
M3*0.5	Machine	5.5~9	6.5~10.5	0.64~1.04	5.2~8.4	0.51~0.82
M3.5*0.6	Machine	8.5~13	10~15	0.98~1.47	8~12	0.78~1.18
M4*0.7	Machine	13~18	15~21	1.47~2.06	12~17	1.18~1.66
M5*0.8	Machine	25~34	29~39	2.84~3.82	23~32	2.26~3.14
M6*1.0	Machine	45~55	52~63.5	5.1~6.22	42~51	4.11~5
M6*1.0	Hex cap	85~112	98~129	9.6~12.65	78~103	7.65~10.1
M8*1.25	Machine	106~141	122~163	11.96~15.98	98~130	9.61~12.75
M8*1.25	Hex cap	205~274	237~316	23.24~30.98	190~253	18.63~24.8
M10*1.5	Hex cap	212~382	245~440	24.02~43.15	196~351	19.22~34.42
M12*1.75	Hex cap	372~668	430~770	42.17~75.49	343~615	33.63~60.3
Screw in Imperial						
2-56	Machine	1.5~2	1.7~2.3	0.17~0.22	1.4~1.8	0.14~0.18
4-40	Machine	3~4	3.5~4.5	0.34~0.44	2.8~3.6	0.27~0.35
6-32	Machine	6~10	7~11.5	0.68~1.13	5.6~9.2	0.55~0.9
8-32	Machine	10~15	11.5~17	1.13~1.66	9.2~14	0.9~1.37
10-32	Machine	16~24	18.5~28	1.81~2.74	15~22	1.47~2.16
1/4-20	Machine	35~46	40~53	3.92~5.2	32~42	3.14~4.11
1/4-20	Hex cap	57~77	66~89	6.47~8.73	53~71	5.2~6.96
5/16-18	Hex cap	119~158	137~182	13.43~17.85	110~145	10.77~14.21
3/8-16	Hex cap	205~274	237~316	23.24~30.99	190~253	18.63~24.82
7/16-14	Hex cap	338~451	390~521	38.24~51.09	312~416	30.59~40.79
1/2-13	Hex cap	515~686	595~792	58.35~77.66	476~634	46.68~62.17



## 3.7 Installation Inspection & Commissioning

### 3.7.1 Environmental Check

Item	Status	Remark
Ambient Temperature		
Ambient Humidity		
Sunshade		Recommended but not required.
Rain Canopy		Recommended for better charging experience and maintenance on rainy day.
Installation Altitude		≤ 2000m (6560 ft)
Air Circulation / Drafty		
Dust Level		
Anti-Vandalism Measures		

### 3.7.2 External Infrastructure Readiness & Check

Item	Status	Remark
Cement (stand) Base		
Input Wirings & Terminals		Type/ Length/cross section
Key & Lock of Cabinet Door		
Fixing Screws		Type /No.
MCCB(Moulded Case Circuit Breaker)		Current rating of MCCB shall be higher than or equal to 600A (360kW)
Residual Current Device		30mA type A
Input Electricity Capacity		
Input Electricity Configuration		Wye
Grounding Resistance		<10Ω
Grounding System		TN/TT
Grid Voltage & Frequency		
Network Connection & Quality		Wi-Fi , 3G/4G > -65dBm



### 3.7.3 EVSE Check – Static (Non-Powered)

Item	Status	Remark
Outlook		No dent, rust ,scratch
Labeling & Warning Signs		
Package (accessory) List		
Inner Wiring & Connection		Refer to 3.6.6
Robustness of Input Wirings		
Robustness of output wiring		



**WARNING:** Improper connection of the EVSE grounding conductor can result in a risk of electric shock. Please ensure the EVSE is properly grounded prior to energize it.





### 3.7.4 Power On Check

1. Turn on the external breaker of power distribution box.
2. Open the power cabinet's front door and check light indication status at power dispenser as shown in following.

#	Status Description	RED Light	GREEN Light
1	Start up	Both are blinking	
2	Standby mode	Off	On
3	Warning or Error	On	Off

3. Function check & Connection as list below.

Item	Status	Remark
Network Connection Quality		Wi-Fi , 3G/4G > -65dBm
Cooling Fans Operation & Noise		
EVSE Setting		See chapter 4 or refer to setting manual
Function of Engineer Mode		

### 3.7.5 EVSE Charging Check

Item	Status	Remark
Full Charge Test		Temperature Reading
Airflow & Noise of Cooling Fan		
Charging Record (log) Upload		



### 3.7.6 EVSE Check –System Power Button

Item	Status	Remark
Emergency Stop Button & Recovery		Set the rated load state, press the emergency stop button, the charger should be cut off output immediately. 1. The charger stops charging and alarm when press the emergency stop button. 2. When the button is released and the gun is pulled, the EVSE returns to standby status.
Tilt sensor and Door open sensor trigger & Recovery		Push self-test button then upstream circuit breaker will be cut off.



## 4. Charger and Network Setting

### 4.1 Wi-Fi Network Setting

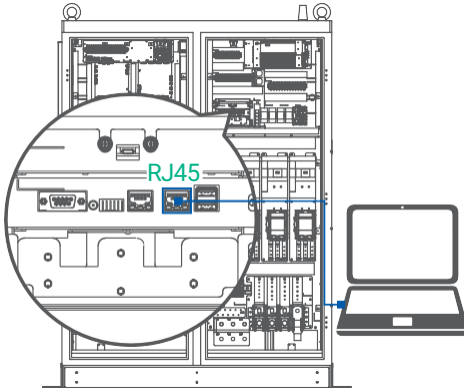

- Laptop with RJ45 interface.
- Connect RJ45 cable from Laptop to charger's RJ45 port.
- Setup parameters in the Webservice.
- Input RJ45 connector port is for engineer use for maintenance.

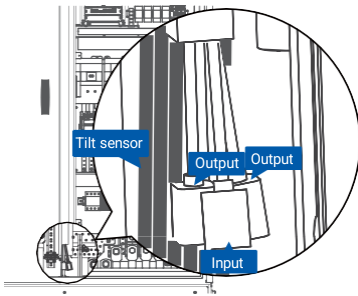
#### Step 1.

Before opening web browser, please enter network setting to set your IPV4 static IP to 192.168.1.1 in PC

#### Step 2.

Open web service browser, type the IP address of charger "192.168.1.10" into the URL bar to access the web page of charger.

- Account: admin
- Password: 1231231238

  
login https://192.168.1.10  
Account   
Password

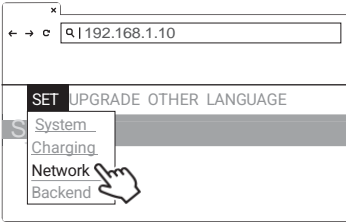

**Step 3.**  
SET -> Network.

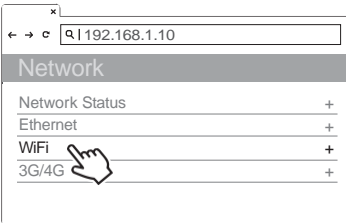

**Step 4.**  
Select Wi-Fi Module  
Select Wi-Fi modes and fill in SSID and Password according to your application, if not required, just keep default.

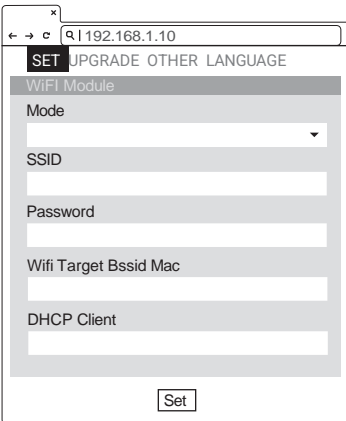

Wi-Fi Setting	Description
Mode	Enable(station) or disable or set as AP mode
SSID	Service Set Identifier SSID
Password	Password to access to Wi-Fi
Wifi Target Bssid Mac	Fill in designated AP Mac if needed
DHCP Client	DHCP client of Wi-Fi



**WARNING:** Due to the different environmental conditions, it is recommended to conduct Wi-Fi and 4G module network signal tests before installation. The RSSI (Received Signal Strength Indication) value suggest to be higher than -65 dBm. If it is lower than this value, it may cause the risk of abnormal Wi-Fi or 4G connection quality or disconnection since the influence of external interference in the environment.



## 4.2 3G/4G Setting

### 4.2.1 SIM Card Installation

#### Step 1.

Open the right door. And you can see the 3G/4G/Wi-Fi module inside the cabinet.

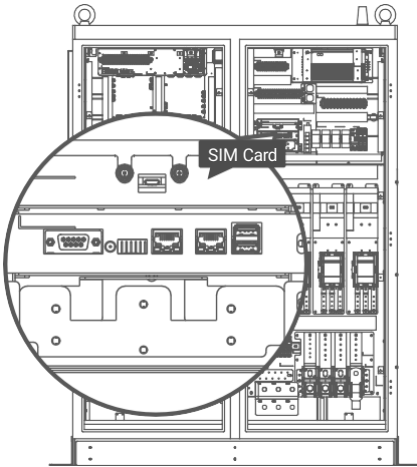

#### Step 2.

Please disable the PIN on the SIM card before inserting it into the SIM card slot. The chip side should be facing downward and its notch is oriented as shown in the left picture. The slot could be damaged if it is inserted in the wrong direction.

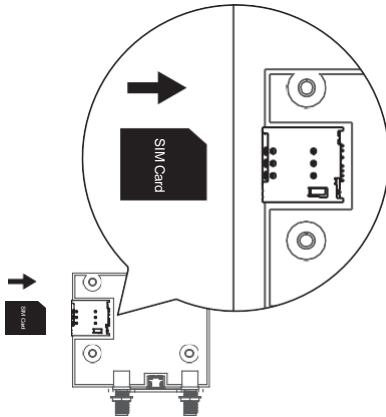



## 4.2.2 Setting and Enable 3G/4G Module.

login https://192.168.1.10

Account

Password

### Step 1.

- Please contact your SIM provider to get the APN, PPP ID and password.
- \*Note: PPP ID and password maybe options depend on your SIM provider.
- Open the web page of charger and sign-in.

← → 192.168.1.10

SET UPGRADE OTHER LANGUAGE

System

Charging

Network

Backend

### Step 2.

SET -> Network.

← → 192.168.1.10

Network

Network Status +

Ethernet +

WiFi +

3G/4G +

### Step 3.

- Network -> 3G/4G Module to fill corresponding information into TelcomApn, TelcomChapPapid and TelcomChapPapPw.
- Please contact your SIM provider to get the APN, PPP ID and password if necessary.
- Click "Set" to finish the setup process. The 3G/4G will be activated in shortly.

← → 192.168.1.10

SET UPGRADE OTHER LANGUAGE

3G/4G

Mode

APN

Network Type

Chap Pap Id

Chap Pap Pwd

Set

3G/4G setting	Description
Mode	Disable or enable 3G/4G
APN	Local telecom
Network Type	2G/3G/4G or auto
Chap Pap Id	Login ID authentication
Chap Pap Pwd	Login password authentication



## 4.3 Time Setting

**Automatic setting :** The time will be adjusted automatically when the charger connects to internet.

Time server :

- [time.windows.com](http://time.windows.com)
- [cn.ntp.org.cn](http://cn.ntp.org.cn)
- [tock.stdtime.gov.tw](http://tock.stdtime.gov.tw)

Note: Firewall and network environment may influence the time server connection

### Manual setting :

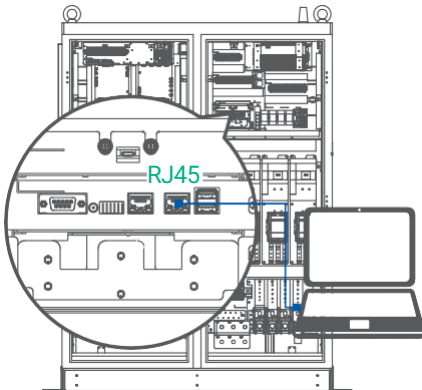

Use the following IP address:

IP address:

Subnet mask:

Default gateway:

Browser window showing login page for https://192.168.1.10

Account:

Password:

### Step 1.

- Laptop with RJ45 interface.
- Connect RJ45 cable from Laptop to charger's RJ45 port.
- Setup parameters in the Webservice.
- Input RJ45 connector port is for engineer use for maintance.

### Step 2.

Before opening web browser, please enter network setting to set your IPV4 static IP to 192.168.1.1 in PC

### Step 3.

Open web service browser, type the IP address of charger "192.168.1.10" into the URL bar to access the web page of charger.

- Account: admin
- Password: 1231231238

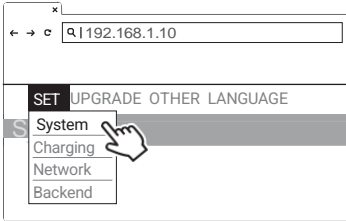

**Step 4.**  
SET -> Network.

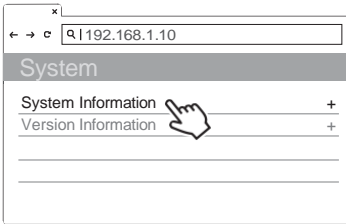

**Step 5.**  
Click "System information".

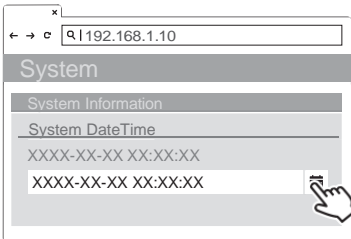

**Step 6.**  
Click system date time.  
Click the calendar button on the right to set the current time.

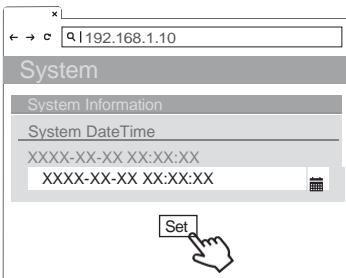

**Step 7.**  
After the setting is completed, click SET and wait until the setting completion window appears.





## 5. Maintenance

### 5.1 Status Codes

- The detail of status code please refer user manual of dispenser.

### 5.2 Before Maintenance

To meet NFPA-70E, OSHA 1910.333 and other Health/safety/security codes, please adhere to the notice and get the permit needed in advance as below:

- 1) Turn off power (Work de-energized whenever possible)
- 2) Lockout/Tagout (LOTO)
- 3) Live work permit (Input terminals with HV after door open)
- 4) Plan the Work/Permit To Work
- 5) Use Personal Protective Equipment (PPE)
- 6) Safe workplace condition & space

#### 5.2.1 Maintenance Check List

Please refer to Appendix for more details.

### 5.3 General Maintenance

- The DC Fast Charger is cooled by forced air. Please keep charger in a ventilated location and do not block the air vents of the DC Fast Charger .
- Please clean or replace the air filters regularly to ensure the DC Fast Charger works properly.
- The housing was made of welding process and surface painting. It is necessary to keep the exterior clean all the time. It's easy to get rusty if not keeping the exterior clean especially in corrosion sensitive environment. Slightly rusty will not affect charger performance, but if charger is serious rusty during or exceed the warranty period, please contact local vendor for instruction.
- Clean the DC fast Charger at least three times a year, keep the exterior clean at all times.
- Clean the outside of the cabinet with damp cloth or wet cotton towel, only use low-pressure tap water and cleaning agents with PH level between 6 to 8.
- Do not apply high-pressure water jets.
- Do not use cleaning agents with abrasive components and do not use abrasive tools. Improper cleaning agents might spoiled coating, painting, surface, brightness and durability of all exterior parts.
- If there is water intruding into the DC Fast Charger then please cut off the power source immediately and contact the DC Fast Charger provider for repair.
- Please make sure the charging connector is returned to the holder of the charging connector after charging to prevent damage.
- If there is damage to the charging connector, charging cable or holder of the



charging connector then please contact the DC Fast Charger provider.

- When using the DC Fast Charger please handle properly. Do not strike or scrape the cabinet or screen.
- If the enclosure or screen is broken, cracked, open or shows any other indication of damage then please contact the Standalone DC Fast Charger provider.



**WARNING:** Danger of electrical shock or injury. Turn OFF power at the panelboard or load center before working on the equipment or removing any component. Do not remove circuit protective devices or any other component until the power is turned OFF.

- Disconnect electrical power to the DC Fast Charger before any maintenance work to ensure it is separated from the supply of AC mains. Failure to do so may cause physical injury or damage to the electrical system and charging unit.

Note:

- Before switching off main breaker to begin maintenance, please record the status code number on the LCD monitor.
- After maintenance door opened or MCCB of charger turned off the charger is still hazardous. Only visual inspection can be operated.
- Maintenance of the DC Fast Charger shall be conducted only by a qualified technician.
- After opening the front door of the DC Fast Charger, turn off the main breaker and auxiliary breaker before any maintenance work.
- Replace the ventilation filter every six to twelve months.
- Please confirm the main power junctions are tightened every month, and rotate cables testing when the power off. If any main power screw is loose will be resulted in damage on charger or smoke on the connections. Please confirm screw torque requirement table.
- Charging cable maintenance: Do not twist, bend the charging cable. The metal contact should not fade or be rusty.
- Please provide the EVSE information including serial number ,model name,status code ,failure behavior and timing ,and also connect the EVSE to the Internet before remote diagnostics and upgrading .



## 5.4 Replacement Kits and Accessories

The DC EVSE offers the following replacement kits and accessories

Replacement Kit List
MW Aux. Power HEP-185-24A
MW Aux. Power HEP-1000-24A
MW Aux. Power HEP-100-12A
Emergency Stop Button
30kW DC PSU U-1K0100
Control & Supervisory Unit (CSU3.1)
Surge Protection Device (SPD)
DC Fan
Air Filters
DC Relay
Fuse
AC Contactor
3G/4G/Wi-Fi board
Relay board
Fan board



## 6. Limited Product Warranty

The warranty period of this charger is according to purchasing contract; two years typically.

Replacement and repair parts manufactured by alternative manufacturers to those on the maintenance parts are only allowed if authorized by supplier.

The housing was made of welding process and surface painting. It is necessary to keep the exterior clean all the time. It's easy to get rusty if not keeping the exterior clean especially in corrosion sensitive environment. Slightly rusty will not affect charger performance, but if charger is serious rusty during or exceed the warranty period, please contact local vendor for instruction.

Warranty Exclusions:

- Damage or rendered non-functional as a result of power surges, lightning, earthquake, fire, flood, pest damage, abuse, accident, misuse, negligence or failure to maintain the product or other event beyond supplier's reasonable control or not arising from normal operating condition.
- Cosmetic or superficial defect, dents, marks or scratches after use.
- Components which are separate from the product, ancillary equipment and consumables, such as door key, RFID card, air filter, fuse, cable, wires and connectors.
- Damage as a result of modifications, alterations or disassembling which were not pre-authorized in writing by supplier.
- Damage due to the failure to observe the applicable safety regulations governing the proper use of the product.
- Installed or operated not in strict conformance with the documentation, including without limitation, not ensuring sufficient ventilation for the product as described in Supplier installation instruction.

If a defect in the product arises and valid claim is received within the warranty period, your sole and exclusive remedy will be for Supplier, at its sole discretion and to extent permitted by law, to

1. Repair the defect in the product at no charge, using new or refurbished parts.
2. Exchange the product with new or refurbished product that is functionally equivalent to the original product.



---

Any remedy hardware product will be warranted for the remainder of the original warranty period or 90 days from delivery to the customer, whichever is longer.

In order to receive the remedy set for above, you must contact supplier during the warranty period and provide the model number, series number, proof of purchase, and date of purchase.

This warranty does not cover the damages caused by adapter usage accident or by other unauthorized operation/service.



## Appendix 1 - Package List

Item	Description	No.	Remark
1	EVSE-Power Cabinet	1	
2	User manual	1	
3	OQC Report	1	
4	Key of cabinet	1	
5	Waterproof Plastic Bolts	4	
6	SPONGE WIRE LR	2	
7	CAT6A FTP RJ45 Plug	2	
8	M16 X L40 screws assembly	2	



## Appendix 2 - Maintenance Peroid

No.	Item	Description	0.5 year	1st year	2nd year	3rd year	4th year	5th year
1	Preventive Maintenance		I	I	I	I	I	I
2	Appearance inspection	Appearance visual inspection	I	I	I	I	I	I
3	System fan	Fan clean and spinning smoothly check	I	I	I	R	I	I
4	Air filter	Air filter, air inlet and outlet clean	I	I	R	I	R	I
5	PCBA	Visible section clean	--	I	I	I	I	R
6	SPD	SPD status indication check	I	I	I	I	I	R
7	DC output bolts torque	Bolts torque check	--	I	I	I	I	I
8	AC input bolts torque	Bolts torque check	--	I	I	I	I	I
9	Emergency stop button	Function check	--	I	I	I	I	R
10	Breaker and RCD	Function check	--	I	I	I	I	R
11	Aux power supply	No maintenance requirement	--	--	--	--	--	R
12	PSU module	No maintenance requirement	--	--	--	--	--	R

**Note:**

Depending on the environment, user may decide the timing of filter replacement.

I: Inspection recommended

R: Replacement recommended

--: No maintenance needed or depend on the situation



## Appendix 3 - Wire and MCCB Recommendation

Model name	Item	Cable (kcmil/AWG)
		UL
180kW	Upsteram Breaker (Over than or equal)	300A
	AC Input cable	350 kcmil (177mm <sup>2</sup> )
	PE Cable	4 AWG (21.15mm <sup>2</sup> )
210kW	Upsteram Breaker (Over than or equal)	400A
	AC Input cable	3/0 AWG *2 (85.01mm <sup>2</sup> )
	PE Cable	3 AWG (26.67mm <sup>2</sup> )
240kW	Upsteram Breaker (Over than or equal)	400A
	AC Input cable	3/0 AWG *2 (85.01mm <sup>2</sup> )
	PE Cable	3 AWG (26.67mm <sup>2</sup> )
270kW	Upsteram Breaker (Over than or equal)	500A
	AC Input cable	250 kcmil *2 (127mm <sup>2</sup> )
	PE Cable	2AWG (33.62mm <sup>2</sup> )





300kW	Upsteram Breaker (Over than or equal)	500A
	AC Input cable	250 kcmil*2 (127mm <sup>2</sup> )
	PE Cable	2AWG (33.62mm <sup>2</sup> )
330kW	Upsteram Breaker (Over than or equal)	600A
	AC Input cable	350 kcmil*2 (177mm <sup>2</sup> )
	PE Cable	1AWG (42.41mm <sup>2</sup> )
360kW	Upsteram Breaker (Over than or equal)	600A
	AC Input cable	350 kcmil*2 (177mm <sup>2</sup> )
	PE Cable	1AWG*1 (42.41mm <sup>2</sup> )



## Appendix 4 - Standard Design Power Cabinet

This user manual also applied for standard design power cabinet

Extend 3 phase 5 wires AC input cable from conduit of concrete base, AC cable expose at least 370mm, PE cable expose at least 300mm and these wires should be with ring terminals.

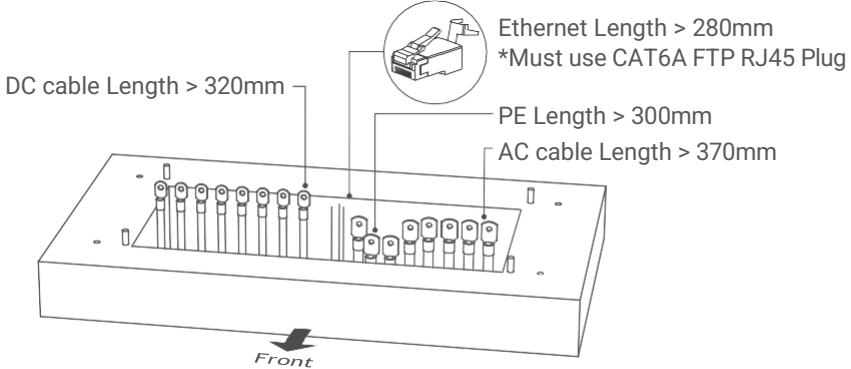
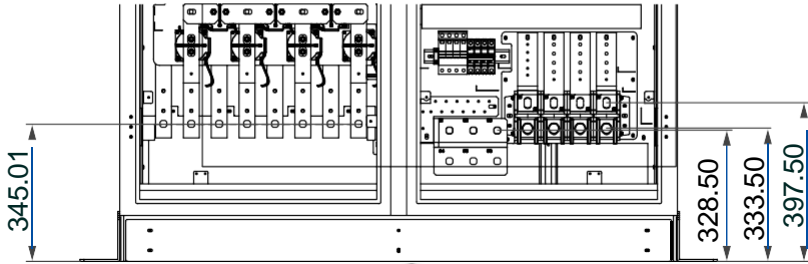



Connect the PE cable (green with yellow) to PE busbar plate; fasten input power cable L1 , L2 , L3 /Neutral on input terminal block accordingly. Connect DC+ and DC- power cable of GUN1、GUN2、GUN3 and GUN4 on relative position of busbar. Please fasten each wire with proper bolt and torque -350Kgf•cm/5-15 secs.

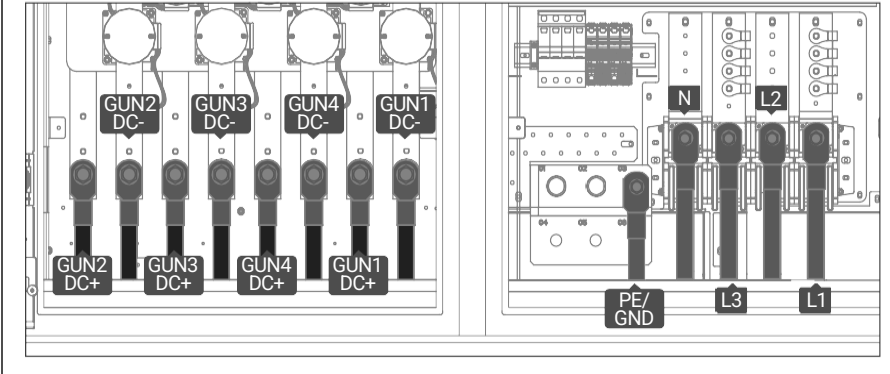







## Manufacturer Contact Info Sticker

